

TOWN OF HEBRON, INDIANA

SANITARY SEWER DESIGN & CONSTRUCTION STANDARDS



APRIL 2021

SANITARY SEWER DESIGN AND CONSTRUCTION STANDARDS

TOWN OF HEBRON, INDIANA

Town Council Members:

Dave Peeler	-	President: Councilman At Large
Justin Albright	-	Vice President: Councilman – Ward 1
Todd Adamczyk	-	Councilman – At Large
Kevin Joseph	-	Councilman – Ward 2
John H. Spinks, Jr	-	Councilman – Ward 3

Town Staff Members:

Jamie Uzelac	-	Clerk-Treasurer
Theodore Fitzgerald	-	Attorney

Consulting Engineer:
Wessler Engineering, Inc.
Indianapolis, Indiana

TOWN OF HEBRON, INDIANA

SANITARY SEWER

DESIGN AND CONSTRUCTION STANDARDS

<u>Section</u>	<u>Description</u>	<u>Page</u>
1	Introduction	1-1
2	Town Checklists and Forms.....	2-1
3	Abbreviations and Definitions	3-1
4	General Rules and Requirements.....	4-1
5	General Design Standards for Sanitary Sewers	5-1
6	Materials for Sanitary Sewers	6-1
7	Sanitary Lift Stations	7-1
8	Installation and Construction of Sanitary Sewers.....	8-1
9	Erosion Control	9-1
10	Inspection, Testing and Acceptance of Sanitary Sewers	10-1
11	Fats, Oil, and Grease (FOG) Requirements	11-1

Appendix A – Standard Forms for Sanitary Sewer Service

Appendix B – Standard Details



SECTION 1

INTRODUCTION

1.01 General

The Town of Hebron is responsible for ensuring the proper installation of all sanitary sewer facilities constructed in or connected to the existing Town facilities. All facilities shall be designed and constructed in accordance with these Standards as well as all applicable State and Federal regulations and requirements.

It shall be the Owner's/Contractor's responsibility to comply with all requirements of the Town or other authority having jurisdiction on work if such authority imposes greater requirements. Furthermore, the Owner shall be responsible for procuring all necessary permits and licenses, pay all charges and fees for acquiring and recording all easements, and giving all notices necessary and incidental to the work.

The Owner/Contractor shall be responsible for obtaining all permits which relate to the design of the completed facilities. Permits obtained by the Owner/Contractor include, but are not limited to, permits from the following:

- Indiana Department of Environmental Management
- Indiana Department of Fire Prevention and Building Safety
- Indiana Department of Natural Resources
- U.S. Army Corps of Engineers
- Construction Storm Water General Permit (formerly Storm Water Associated with Construction Activities, 327 IAC 15-5 or Rule 5)
- Applicable County and local permits

Addenda and/or revisions to these Standards may be issued periodically and will be distributed and made available to the public and contractors at the Town Hall. Users shall be responsible to keep apprised of any changes and revisions to these Standards.

Any conflicts between these Standards and any applicable State laws shall be superseded by such law. If any conflict arises between these Standards and applicable Town or County Ordinances, these Standards shall prevail. These Standards are approved and adopted by the Town Council, Town of Hebron.



DESIGN AND CONSTRUCTION STANDARDS

The purpose of these Standards is to establish a minimum criteria for design and workmanship. The Sanitary Sewer Design and Construction Standards shall have jurisdiction over the entire sanitary sewer system and appurtenances from the point of connection with the building plumbing to the final point of discharge at the treatment facility.

SECTION 2
TOWN CHECKLISTS AND FORMS

<u>Description</u>	<u>Page</u>
Sanitary Sewer Procedural Checklist	2-1
Plan and Specification Review Checklist.....	2-3
Lift Station Inspection Checklist	2-5
Pressure Test Report	2-12



DESIGN AND CONSTRUCTION STANDARDS

TOWN OF HEBRON, INDIANA

**SANITARY SEWER
PROCEDURES FOR CONSTRUCTION (CHECK LIST)**

Date Received/ Requested	Date Appr./ Sent	PROJECT NO.: _____
		PROJECT NAME: _____
_____	_____	1. Initial Coordination meeting including Developer, Planning Administrator (PA), and Town's Engineer.
_____	_____	2. Developer submits preliminary plans of proposed development with estimated capacity demand to the PA for preliminary review and response, and Application for Sewer Service.
_____	_____	3. Developer submits three (3) sets of construction plans and the completed Contract Form for Sewer Service to the PA.
_____	_____	4. PA will forward construction plans to the Town's Engineer for review and report to the Town Council on the Sewer Service request.
_____	_____	5. Town's Engineer will review the plans for completeness, conformance with the Town's standards, and evaluate whether the existing collection system can accommodate the sewage generated by this project. The Town's Engineer will identify necessary changes in the plans.
_____	_____	6. The Town's Engineer will submit review letter which will recommend (or not recommend) approval of the plans for construction to the PA.
_____	_____	7. After payment of required fees, the Sewer Service Agreement is executed by the Town and Developer and recorded by the Town.
_____	_____	8. Developer transmits Bond and insurance certificate.
_____	_____	9. Developer receives construction authorization from the PA.
_____	_____	10. Developer notifies PA two (2) weeks in advance that project is ready for construction.



DESIGN AND CONSTRUCTION STANDARDS

Date Received/ Requested	Date Appr./ Sent	
_____	_____	11. The Developer's Contractor begins construction by notifying the PA at least 24 hours in advance of beginning work.
_____	_____	12. Following installation of the sewers, the Developer's Contractor conducts air tests, mandrel tests, manhole tests, and CCTV inspection of the new sewers.
_____	_____	13. The Developer's Engineer submits two (2) sets of proposed record drawings (prints) (and any easements required but not already included in approved plat) to the PA for review.
_____	_____	14. The Town's Engineer prepares a punch list for the project.
_____	_____	15. The Developer's Contractor completes punch list items.
_____	_____	16. The Town's Engineer reinspects the project.
_____	_____	17. The Developer's Engineer submits two (2) sets of final prints and an electronic version (in a format acceptable to the Town) of the approved record drawings for the Town's files, along with CCTV videos.
_____	_____	18. Developer submits Maintenance Bond to the PA.
_____	_____	19. The Town's Engineer recommends approval for acceptance for maintenance to the Town.
_____	_____	20. All easements (if not already included in approved plat) are accepted by the Town, then recorded by the Developer.
_____	_____	21. Developer submits required documentation for dedication or transfer of sewer system to PA for Town's approval. After payment of any remaining fees and reimbursable expenses, the Town approves the sewer system for acceptance.



**TOWN OF HEBRON, INDIANA
PLAN & SPECIFICATION REVIEW CHECKLIST**

NAME OF PROJECT: _____

DESIGN ENGINEER: _____

I. Completeness and Conformance With Town Standards

- A. Manholes & Cleanouts
 - 1. Manhole Numbers, Rim & Invert Elevations _____
 - 2. Manhole/Cleanout Materials & Construction _____
 - 3. Spaced Max of 400' Apart _____
 - 4. Standard Manhole: 5' Deep or Greater _____
 - 5. Shallow, flat top, Manholes: Less than 5' _____
 - 6. Drop Manhole: 2' Drop of Greater _____
 - 7. Manholes at Finish Grade _____
 - 8. Details Complete _____
 - 9. Specs Complete _____
- B. Gravity Sewer Pipe
 - 1. Pipe Numbers, Lengths, Sizes (8" Min.), and Slopes _____
 - 2. All Sewer Lines Planned and Profiles _____
 - 3. Depth: 3' Min. to Top of Pipe _____
 - 4. Pipe Materials _____
 - 5. Pipe Bedding & Backfill Materials & Construction _____
 - 6. Depth Restrictions _____
 - 7. Details Complete _____
 - 8. Specs Complete _____
- C. Laterals & Wyes
 - 1. Wyes Connected to Sewer, Not Manholes _____
 - 2. Basement Connection Requirements (See Specs) _____
 - 3. Pipe Size: 6" Min. _____
 - 4. Lateral Provided for All Lots _____
 - 5. Pipe Material _____
 - 6. Lateral Locations, Length Indicated on Plans _____
 - 7. Pipe Slope: Min. 1% _____
 - 8. Details Complete _____
 - 9. Specs Complete _____
- D. Force Main
 - 1. Pipe and Fitting Material _____
 - 2. Valve Types & Materials _____
 - 3. Pipe Size: 4-Inch Min. _____
 - 4. Depth: 3' Min. to Top of Pipe _____
 - 5. Pipe Bedding & Backfill Materials & Construction _____
 - 6. Specs Complete _____
 - 7. Details Complete _____
 - 8. Air/Vacuum Release Stations _____



DESIGN AND CONSTRUCTION STANDARDS

- E. Pump Stations
 - 1. Wet Well Size: Min. 15 Minute Detention Time
 - 2. Pump Capacity: Min. 100 GPM
 - 3. Pump Able to Pass 3-inch Sphere
 - 4. Double Mechanical Seals
 - 5. Piping Inside Station: D.I. Class 50.....
 - 6. NEMA 4X Enclosure for Controls
 - 7. Access Road & Fencing
 - 8. Specs Complete
 - 9. Details Complete
 - F Connections to Existing Sewers
 - 1. Details of Connections.....
 - 2. Existing Sewer Sizes & Materials Indicated
 - 3. Compare Existing Sewers to Town and Sewer Map
 - 4. Connection to Existing Sewer Made Using New Manhole Over Line
 - G. Other Utility Conflicts
 - 1. Horizontal Separation of 10' Min. to Water Lines
 - 2. Vertical Separation of 18" to Water Lines
 - 3. Horizontal & Vertical Separation Between Other Utilities
 - H. Miscellaneous
 - 1. Easement Widths: 15' wide-force mains; 20' wide <15' deep; 25' wide – 15-22' deep; 30' wide >22' deep
 - 2. Engineer's Seals & Signature
 - 3. Page Numbers, Set Complete
 - 4. Specs Complete
 - 5. North Arrow on Each Sheet.....
 - 6. Benchmark Indicated on Plans
 - 7. Scale Indicated on Plans
 - 8. Roads Labeled
 - 9. Contours Labeled.....
 - 10. Existing & Final Grade Shown on Profiles
 - 11. Check Additional Notes, Details, Spec. Sections
- II. Calculations
- A. Design Flow
 - 1. 100 Gallons Per Capita Per Day or 310 Per House Per Day
 - 2. Use 10-States Peaking Factors

III. Project Cost Estimate

PLAN REVIEW DATE:
LETTERS SENT:
PLANS RESUBMITTED:
APPROVAL DATE:



**Town of Hebron, Indiana
Submersible Lift Station
Final Inspection Checklist**

Date: _____	Location: _____
Lift Station ID: _____	KW Meter Number: _____
Pump Manufacturer: _____	Pump Supplier: _____
Pump Model: _____	Serial number: _____
Voltage: _____	Phase: _____
Hertz: _____	Horsepower: _____
Control Panel model: _____	Control Panel Supplier: _____
Contractor: _____	Engineer: _____

I. Electric

- A. Is the power system 3 phase or 1 phase? Yes No
- B. If 3 phase, is grounded neutral power provided? Yes No
- C. If above answer is "No" is transformer installed? Yes No
- D. Voltage readings
1. Between phases: L1, L2 _____ L1, L3 _____ L2, L3 _____
2. High phase to ground _____
3. Other legs to ground _____
- E. High Leg (L3) is connected to motor only and not connected to any auxiliary circuits. Yes No
- F. Do latches on control panel work smoothly? Yes No



II. PUMP AND MOTOR CONTROLS

- A. Breaker switches operate property:
- | | | | | |
|---------------------------|--------------------------|-----|--------------------------|----|
| 1. Pump # 1 | <input type="checkbox"/> | Yes | <input type="checkbox"/> | No |
| 2. Pump # 2 | <input type="checkbox"/> | Yes | <input type="checkbox"/> | No |
| 3. Pump # 3 | <input type="checkbox"/> | Yes | <input type="checkbox"/> | No |
| 4. Control Circuit | <input type="checkbox"/> | Yes | <input type="checkbox"/> | No |
| 5. Remote Control Monitor | <input type="checkbox"/> | Yes | <input type="checkbox"/> | No |
- B. Hand-Off-Automatic switches:
- | | | | | |
|--|--------------------------|-----|--------------------------|----|
| 1. Pump #1 hand position operates | <input type="checkbox"/> | Yes | <input type="checkbox"/> | No |
| 2. Pump #2 hand position operates | <input type="checkbox"/> | Yes | <input type="checkbox"/> | No |
| 3. Pump #3 hand position operates | <input type="checkbox"/> | Yes | <input type="checkbox"/> | No |
| 4. Pump #1 Auto position operates | <input type="checkbox"/> | Yes | <input type="checkbox"/> | No |
| 5. Pump #2 Auto position operates | <input type="checkbox"/> | Yes | <input type="checkbox"/> | No |
| 6. Pump #3 Auto position operates | <input type="checkbox"/> | Yes | <input type="checkbox"/> | No |
| 7. Do the floats sequence all pumps with relation to lead, lag, and alternation: | <input type="checkbox"/> | Yes | <input type="checkbox"/> | No |
- C. Amperage:
- | | | | | |
|--|--------------------------|-----|--------------------------|----|
| 1. Name Plate Rating (amps) Pump # 1 Motor | <input type="checkbox"/> | Yes | <input type="checkbox"/> | No |
| 2. Amps pulled by Pump #1 Motor | <input type="checkbox"/> | Yes | <input type="checkbox"/> | No |
| 3. Name Plate Rating (amps) Pump #2 Motor | <input type="checkbox"/> | Yes | <input type="checkbox"/> | No |
| 4. Amps pulled by Pump #2 Motor | <input type="checkbox"/> | Yes | <input type="checkbox"/> | No |
| 5. Name Plate Rateing (amps) Pump #3 Motor | <input type="checkbox"/> | Yes | <input type="checkbox"/> | No |
| 6. Amps pulled by Pump #3 Motor | <input type="checkbox"/> | Yes | <input type="checkbox"/> | No |
- D. Seal Failure/Heat Sensor:
- | | | | | |
|---|--------------------------|-----|--------------------------|----|
| 1. Seal failure wires connected properly to seal failure circuit: | <input type="checkbox"/> | Yes | <input type="checkbox"/> | No |
| 2. Test seal failure circuit OK? | <input type="checkbox"/> | Yes | <input type="checkbox"/> | No |
| 3. Heat sensor wires connected properly to heat sensor circuit: | <input type="checkbox"/> | Yes | <input type="checkbox"/> | No |
| 4. Test heat sensor circuit OK? | <input type="checkbox"/> | Yes | <input type="checkbox"/> | No |
- E. Control Components:
- | | | | | |
|---|--------------------------|-----|--------------------------|----|
| 1. Verify all electrical components are locally available | <input type="checkbox"/> | Yes | <input type="checkbox"/> | No |
|---|--------------------------|-----|--------------------------|----|
- F. Alarms:
- | | | | | |
|--|--------------------------|-----|--------------------------|----|
| 1. High water alarm light and horn activate with test button | <input type="checkbox"/> | Yes | <input type="checkbox"/> | No |
| 2. Horn silences with silence button. | <input type="checkbox"/> | Yes | <input type="checkbox"/> | No |
| 3. High water alarm light and horn activate with float. | <input type="checkbox"/> | Yes | <input type="checkbox"/> | No |



DESIGN AND CONSTRUCTION STANDARDS

G. Float Settings:

1. Lead pump kicks on at Elv. _____ from wet well bottom
2. Lead pump kicks off at Elv. _____ from wet well bottom
3. Lag pump kicks on at Elv. _____ from wet well bottom
4. Lag pump kicks off at Elv. _____ from wet well bottom
5. Back up pump kicks off at Elv. _____ from wet well bottom
6. Back up pump kicks of at Elv. _____ from wet well bottom
7. Height of influent sewer above floor of wet well _____
8. Height of high water alarm above floor of wet well _____
9. Top of basin Elev. _____
10. Total basin depth _____

Remarks:

III. Pumps and Motors

A. Operation:

1. Are pumps running quietly?
 - a. Pump # 1 Yes No
 - b. Pump # 2 Yes No
 - c. Pump # 3 Yes No
2. Are motors running quietly?
 - a. Pump #1 Yes No
 - b. Pump # 2 Yes No
 - c. Pump # 3 Yes No
3. Is excessive vibration noted:
 - a. Pump #1 Yes No
 - b. Pump # 2 Yes No
 - c. Pump #3 Yes No

B. Installation

1. Are guide rails exactly vertical (plumb)? Yes No
2. Is base elbow installed level? Yes No

Remarks:



DESIGN AND CONSTRUCTION STANDARDS

IV. Remote Monitor Panel

- A. Verify start-up procedure completed properly and put "On-Line" with the Wastewater Plant by remote monitor panel supplier. Yes No

V. Valves

- A. Check valves:
1. Do clappers swing freely? Yes No
 2. Does packing leak? Yes No
 3. Are counter weights adjusted properly? Yes No
- B. Plug valves:
1. Do valves open and close freely? Yes No
 2. Does packing leak? Yes No
 3. During operation, are all gates completely open? Yes No

Remarks:

VI. Pump Station Testing

- A. Draw Down Test

Diameter of wet well _____
(5'-0" = 150 gal/ft 6'-0"-212 gal/ft 7'-0"-288 gal/ft 8'-0"-376 gal/ft)



DESIGN AND CONSTRUCTION STANDARDS

	Time	Depth	Vol. Per Unit Depth	Total Vol.	Pump Capacity
Pump # 1 On	_____	_____	_____	_____	_____
Pump # 1 Off	_____	_____	_____	_____	_____
Pump # 2 On	_____	_____	_____	_____	_____
Pump # 2 Off	_____	_____	_____	_____	_____
Pump # 3 On	_____	_____	_____	_____	_____
Pump # 3 Off	_____	_____	_____	_____	_____
Pump # 4 On	_____	_____	_____	_____	_____
Pump # 4 Off	_____	_____	_____	_____	_____
Pump #1, 2 On	_____	_____	_____	_____	_____
Pump #1, 2 Off	_____	_____	_____	_____	_____
Pump #1, 3 On	_____	_____	_____	_____	_____
Pump #1, 3 Off	_____	_____	_____	_____	_____
Pump #2, 3 On	_____	_____	_____	_____	_____
Pump #2, 3 Off	_____	_____	_____	_____	_____
Pump #1, 4 On	_____	_____	_____	_____	_____
Pump #1, 4 Off	_____	_____	_____	_____	_____
Pump # 2, 4 On	_____	_____	_____	_____	_____
Pump # 2, 4 Off	_____	_____	_____	_____	_____
Pump #3, 4 On	_____	_____	_____	_____	_____
Pump #3, 4 Off	_____	_____	_____	_____	_____



DESIGN AND CONSTRUCTION STANDARDS

- B. Pressure Test
1. No Pumps Running – Static Back Pressure: _____
 2. Pump No. 1 Operating – Pressure: _____
 3. Pump No. 2 Operating – Pressure: _____
 4. Pump No. 3 Operating – Pressure: _____
 5. Pump Nos. 1 & 2 Running – Pressure: _____
 6. Pump Nos. 2 & 3 Running – Pressure: _____
 7. Pump Nos. 1 & 3 Running 0 Pressure: _____

Remarks: _____

VII. Equipment

- A. Pumps
- B. Motors
- C. Pump Circuit Breaker
- D. Starters
- E. Heaters
- F. Control Circuit Breaker
- G. Remote Monitor Circuit Breaker
- H. Alternator
- I. H-O-A Switches
- J. Plug Valves
- K. Check Valves
- L. Pressure Gauge
- M. Transducer



DESIGN AND CONSTRUCTION STANDARDS

N. Floats

O. Other

Remarks:

VIII. Covert Alarm System

A. Do latches on control panel work smoothly? Yes No

B. Code indication functioning

1. Pump overload trip Yes No

2. Crew on site key switch Yes No

3. Wet well high water Yes No

4. Dry pit high water or submersible seal failure Yes No

5. Power failure Yes No

6. Open Yes No

7. Restore to normal Yes No

8. Low battery Yes No

Remarks:

I CERTIFY THIS REPORT IS ACCURATE

Start-up date/time

Start-up Coordinator

Factory Representative

Wastewater Utility Superintendent

Wastewater Utility Operator

Engineer

Contractor



HYDROSTATIC TEST

DATE: _____

TEST TYPE:

WATER MAIN:

SANITARY FORCE MAIN:

JOB NAME: _____

JOB NUMBER: _____

CONTRACTOR: _____

TESTER: _____
 INSPECTOR/
 ENGINEER: _____

TEST DATA:

PIPE SIZE: _____	TYPE: _____	LENGTH: _____	ft
LOCATION OF TEST: _____			
END POINT LOCATIONS: _____			
REQUIRED TEST PRESSURE: _____	psi	ACTUAL TEST PRESSURE: _____	psi
TEST START TIME: _____		TEST START PRESSURE: _____	psi
TEST STOP TIME: _____		TEST STOP PRESSURE: _____	psi
DURATION OF TEST: _____	hr.	PRESSURE DROP: _____	psi
WATER ADDED: _____	gal	ALLOWABLE LOSS: _____	gal/hr
TEST RESULT:	PASS: <input type="checkbox"/>	FAIL: <input type="checkbox"/>	
REMARKS: _____			
AUTHORIZED SIGNATURES:			
CONTRACTOR: _____		DATE: _____	
TESTER: _____		DATE: _____	
INSPECTOR/ ENGINEER: _____		DATE: _____	

SECTION 3
ABBREVIATIONS AND DEFINITIONS

<u>Section</u>	<u>Description</u>	<u>Page</u>
3.01	Abbreviations and Definitions	3-1
	A. Abbreviations	3-1
	B. Definitions	3-2



SECTION 3

ABBREVIATIONS AND DEFINITIONS

3.01 *Abbreviations and Definitions*

Construction work, alterations, repairs, mechanical installations and appliances connected therewith shall comply with the State Building rules and regulations of the Indiana Department of Fire and Building Services, Indiana Department of Environmental Management, local municipal ordinances, and other statutory provisions pertaining to this class of work; such rules, regulations, and ordinances are to be considered part of these Specifications.

Wherever in these Standards the following terms, abbreviations, or definitions are used, the intent and meaning shall be interpreted as follows:

A. Abbreviations

AAR	Association of American Railroads
AASHTO	American Association of State and Highway and Transportation Officials
A-E	Architect/Engineer
AGA	American Gas Association
AIA	American Institute of Architects
ANSI	American National Standards Institute
ARA	American Railway Association
AREA	American Railway Engineering Association
ASCE	American Society of Civil Engineers
ASLA	American Society of Landscape Architects
ASME	American Society of Mechanical Engineers
ASTM	American Society for Testing and Material
AWPA	American Wood-Preservers Association
AWS	American Welding Society
AWWA	American Water Works Association
CTR	Contractor
ETL	Electrical Testing Laboratory
Fed.Spec.	Federal Specifications
FHWA	Federal Highway Administration, Department of Transportation
FM	Associated Factory Mutual Laboratories
FSS	Federal Specifications and Standards, General Services Administration



DESIGN AND CONSTRUCTION STANDARDS

IDEM	Indiana Department of Environmental Management
IDNR	Indiana Department of Natural Resources
INDOT	Indiana Department of Transportation
IPCEA	Insulated Power Cable Engineers Association
ISPC	Indiana State Plumbing Code
NAVFAC	U.S. Naval Facilities Engineering Command
NEMA	National Electrical Manufacturers Association
NFPA	National Fire Protection Association
ONR	Owner
OSHA	Occupational Safety and Health Act of 1970
SAE	Society of Automotive Engineers
S-CTR	Sub-Contractor
SPECS	Specifications
SSPC	Steel Structures Painting Council
UL	Underwriter's Laboratories, Inc.
WWPA	Western Wood Producers

B. Definitions

Acceleration Lane: An added auxiliary roadway lane that permits integration and merging of slower moving accelerating vehicles into the main vehicular stream.

Acceptance: The formal written acceptance by the Town of Hebron (Town) of an entire project which has been completed in all respects in accordance with the approved Plans, Specifications, and these Standards including any previously approved modifications thereof.

Access Road: A street designed to provide vehicular access to abutting property.

Adequate Public Facilities: Facilities determined to be capable of supporting and servicing the physical area and designated intensity of the proposed subdivision as determined by the Town Council based upon specific levels of service.

Alley: A public or private way, at the rear or side of property, permanently reserved as a means of secondary vehicular access to abutting property. Frontage on said alley shall not be construed as satisfying the requirements of any Ordinance related to frontage on a dedicated street.

Backfill: Earth and/or other material used to replace material removed from trenches during construction which is above the pipe bedding.



DESIGN AND CONSTRUCTION STANDARDS

Bedding: That portion of the trench backfill which encases the sewer or water pipe to a minimum depth above and below the bell/barrel of the pipe for the purpose of properly supporting the pipe.

Block: The Property abutting on one side of a street between two nearest intersecting streets, railroad right-of-ways, or natural barriers.

Building Sewer (lateral): The conduit for transporting waste discharged from the building to the public sewer commencing three (3) feet outside the building walls and ending at the wye or tee fitting at the connection to the public sewer.

Capacity of a Storm Drainage Facility: The maximum flow that can be conveyed or stored by a storm drainage facility without causing damage to public or private property.

Catch Basin: An inlet designed to intercept and redirect surface waters.

Channel: A natural or artificial watercourse which periodically or continuously contains moving water, or which forms a connecting link between two (2) bodies of water. It has a defined bed and banks, which serve to confine the water.

Collector Road: A road intended to move traffic from Local Neighborhood Streets to Arterials Roadways. A Collector Road serves a neighborhood or large subdivision and provides access to adjacent property. The width and other design criteria for Collector Roads allow for greater mobility than Local Streets.

Comprehensive Plan: A plan, or any portion thereof, adopted by the Town Council, showing the general location and extent of present and proposed physical facilities including residential, industrial, and commercial uses, major streets, parks, schools, and other community facilities. This plan establishes the goals, objectives, and policies for the physical development of the Town.

Contractor: Any Contractor who meets the Town's requirements and is licensed to enter into contracts for and to perform the work of installing sewers.

Construction Plan: The maps or drawings accompanying a subdivision plat and showing the specific location and design of improvements to be



DESIGN AND CONSTRUCTION STANDARDS

installed in the subdivision in accordance with the requirements of the Plan Commission as a condition of the approval of the plat.

County: The County of Porter, State of Indiana

Cul-de-Sac: A local street with only one outlet that terminates in a vehicular turnaround and having an appropriate convenient reversal of terminal for the safe and traffic movement.

Culvert: A closed conduit used for the passage of surface drainage water under a roadway, railroad, canal, or other impediment.

Curb: A concrete boundary usually marking the edge of the street for paved area. Concrete rolled curb, combined concrete curb and gutter, and concrete barrier curb are examples of curb types permitted in the Town of Hebron.

Curb Corner Radius: Radius of curbed roadway edge.

Curb Cut: The opening along the curb line at which point vehicles may enter or leave the roadway.

Design Criteria: Standards that set specific improvement requirements.

Drainage: Surface water runoff and the removal of water from land by drains, grading, or other means during and after construction or development.

Drainage Area: The area from which water drains to a point of consideration.

Drop Manhole: A manhole having a vertical drop pipe connecting the inlet pipe to the elevation of the outlet pipe. The vertical drop pipe shall normally be located immediately outside the manhole.

Easement: Authorization by a property owner for another to use the owner's property for a specified purpose.

Elevation: A vertical distance above or below a fixed reference level, or a flat scale drawing of the front, rear, or side of a building.

Engineer: The Engineer for the Owner.



DESIGN AND CONSTRUCTION STANDARDS

Erosion: The detachment and movement of soil, sediment, or rock fragments by water, wind, ice, or gravity.

Erosion and Sediment Control Measure: A practice or a combination of practices to control erosion and resulting off-site sedimentation.

Erosion and Sediment Control Plan: A written description and drawings of pertinent information concerning erosion and sediment control measures designed to meet the requirements of these Standards.

Excavation: Removal by any means whatsoever of soil, rock, minerals, mineral substances, or organic substances (other than vegetation), from water or land on or beneath the land surface thereof, whether exposed or submerged.

Existing Grade or Elevation: The vertical location of the ground surface prior to excavating or filling.

Flood Elevation: The maximum level of high waters for a flood of given return period and rainfall duration.

Flood Hazard Area: Any floodplain, floodway, floodway fringe, or any combination thereof, which is subject to inundation by the regulatory flood or any floodplain as delineated by Zone A on the current Flood Hazard Boundary Map of the Federal Emergency Management Agency.

Floodplain: The area adjoining the river or stream which has been or may be covered by floodwaters. It consists of both the floodway and floodway fringe.

Flood Protection Grade: An elevation which is a specific distance above the regulatory flood elevation as established by agencies having jurisdiction.

Floodway Fringe: That portion of the floodplain lying outside the floodway which is inundated by the regulatory flood.

Frontage: All the property fronting on one side of a street between the two nearest intersecting streets, measured along the line of the street, or if dead-ended, then all of the property abutting on one side between an intersecting street and the dead-end of the street.



DESIGN AND CONSTRUCTION STANDARDS

Frontage Street: Any street constructed adjacent to a Thoroughfare Road for the purpose of providing a high degree of access to adjacent property.

Grade: The average level of the finished surface of the ground adjacent to the exterior walls of the building or structure. May also refer to the slope of a roadway along the centerline.

Gradient: The inclination or slope of a channel, conduit, or natural ground surface expressed as a ratio of the vertical rise or fall to the corresponding horizontal distance.

Highway, Limited Access: A freeway or expressway providing a corridor for through traffic, in respect to which owners or occupants of abutting property on lands and other persons have no legal right to access to or from the same, except at such points and in such manner as may be determined by the public authority having jurisdiction over the traffic way.

Infiltration/Inflow: The total quantity of water from both infiltration and inflow without distinguishing the source.

Infiltration: groundwater or stormwater that enters the sanitary sewer system through cracks and/or leaks in sanitary pipes.

Inflow: Stormwater that enters the sanitary sewer system through a direct connection.

Inlet: An opening into a storm sewer system for the entrance of surface water runoff, more specifically defined as a storm water inlet.

Inspector: An agent of the Town assigned to make detailed inspections of any or all portions of the work and materials. The inspector has full authority to reject materials and/or any portion of the work not supplied and installed in accordance with these Standards.

Intersections: The confluence of two or more public streets or roads.

Intersections Sight Distance: Distance required for a motorist to recognize an on-coming vehicle and safely pull into the roadway without requiring an on-coming vehicle to slow down significantly. See INDOT Design Manual or AASHTO Green Book for specific design and measurement criteria.

Land Disturbing Activity or Non-Agricultural Land Disturbing Activity: Any manmade change of the land surface including removing vegetative cover,



DESIGN AND CONSTRUCTION STANDARDS

excavating, filling, transporting, and grading. It includes any activity requiring a Town of Hebron Improvement Location Permit but does not include agricultural land uses.

Lift Station: Any arrangement of pumps, valves, and controls that lift and/or convey wastewater to a higher elevation.

Local Government: The Town Council of the Town of Hebron.

Local Road: A road whose sole function is to provide access to abutting properties and to other roads from individual properties and to provide right-of-way beneath it for sewer, water, and storm drainage pipes.

Maintenance Guarantee: Any security that may be required and accepted by the Town Council to assure that necessary improvements will function as required for a specific period of time.

Manhole: A storm or sanitary sewer structure, through which a person may enter to gain access to a storm or sanitary sewer or other enclosed structure. A manhole may also be an inlet for the storm sewer system.

Monument: A permanent marker conforming to the requirements of these Standards used to identify the location of a property corner or other survey point

Municipality: See *Local Government*.

Non-Residential Subdivision: A subdivision whose intended use is other than residential, such as commercial, or industrial.

Official Zoning Map: The map established by the Town Council, pursuant to law, showing the streets, highways, parks, drainage systems, and setback lines laid out, adopted, and established by law, and any amendments or additions thereto adopted by the Town Council resulting from the approval of subdivision plats by the Plan Commission and the subsequent filing of the approved plats.

Off-Site: Any premises not located within the area of the property to be subdivided, whether or not in the common ownership of the applicant for subdivision approval.



DESIGN AND CONSTRUCTION STANDARDS

Other Specifications and Materials: Wherever in these Standards other specifications or regulations are mentioned, it shall be understood that the materials and methods mentioned therewith shall conform to all requirements of the latest revision of the specifications so mentioned.

Owner: Any individual, partnership, firm, corporation, or other entity who, as property owner, is initiating the work.

Parking Area: An area designated for stopped, unoccupied motor vehicles.

Pavement: That part of a street having an improved surface or brick, paving stone, concrete, or asphalt placed on the surface of the land.

Pavement Markings: Painted, thermoplastic, or other Town approved method of providing regulatory striping, including turn lane arrows and “Only” designations, onto the street or road surface.

Perimeter Street: Any existing street to which the parcel of land to be subdivided abuts on only one (1) side.

Plans: Construction plans, including system maps, sewer plans, and profiles, cross sections, utility plans, detailed drawings, etc., or reproductions thereof, approved or to be approved by the Town Engineer which show location, character, dimensions, and details of the work to be done.

Primary Arterial: A road intended to move through traffic to and from major attractors such as business districts, regional shopping centers, colleges and/or universities, military installations, major industrial areas, and similar traffic generators within the governmental unit; and/or as a route for traffic between communities or large areas and/or which carries high volumes of traffic. Access to adjacent property should be limited for Primary Arterials.

Primary Plat: The primary drawing or drawings, indicating the proposed layout of the subdivision to be submitted to the Plan Commission for approval.

Project: All work to be completed under the Town’s permit in accordance with the approved plans, specifications, these Standards, and the permit conditions.



DESIGN AND CONSTRUCTION STANDARDS

Record Drawings (As-Builts): Plans certified, signed, and dated by a professional engineer registered in the State of Indiana, indicating that the Plans have been reviewed and revised, if necessary, to accurately show all as-built construction and installation details including, but not limited to, key elevations, locations, and distances.

Registered Engineer: An engineer properly licensed and registered in the State of Indiana.

Regulatory Signs: Signs established by Ordinance and posted within the public road right-of-way to control motorist behavior (Stop signs, No Parking signs, etc.).

Right-of-Way: A strip of land occupied or intended to be occupied by a street, crosswalk, railroad, road, electric transmission line, oil or gas pipeline, water main, sanitary or storm sewer main, shade trees, or for any other special use. The usage of the term “right-of-way” for land platting purposes shall mean that every right-of-way hereafter established and shown on a secondary plat is to be separate and distinct from the lots or parcels adjoining such right-of-way and not included within the dimensions or areas of such lots or parcels. Rights-of-way intended for streets, crosswalks, water mains, sanitary sewers, storm drains, shade trees, or any other use involving maintenance by a public agency shall be dedicated to public use by the maker of the plat on which such right-of-way is established.

Road Classification: For the purpose of providing for the development of the streets, highways, roads and rights-of-way in the governmental unit, and for their future improvement, reconstruction, realignment, and necessary widening, including provision for curbs and sidewalks, each existing street, highway, road, right-of-way, and those located on approved and filed plats, have been designated on the Official Thoroughfare Plan of the Town and classified therein. The classification of each street, highway, road, and right-of-way is based upon its location in the respective zoning districts of the Town and its present and estimated future traffic volume and its relative importance and function as specified in the Comprehensive Plan of the Town. The required improvements shall be measured as set forth for each street classification on the Official Thoroughfare Plan.

Road Centerline Radius: Horizontal alignment of the center of the paved roadway surface.



DESIGN AND CONSTRUCTION STANDARDS

Road, Dead-End: A road or a portion of a road with only one (1) vehicular-traffic outlet (not including cul-de-sacs).

Road Right-of-Way Width: The distance between property lines measured at right angles to the centerline of the street.

Road Tangent Section: Portion of a road or street that has a straight horizontal alignment.

Road Vertical Curve: Vertical alignment of road centerline.

Secondary Arterial: A road intended to collect and distribute traffic in a manner similar to primary arterials, except that these roads service minor traffic-generating areas such as community commercial areas, primary and secondary educational facilities, hospitals, major recreational areas, churches, and offices, and are designed to carry traffic from collector streets to the system of primary arterials. (Access to adjacent property should be limited from Secondary Arterials.)

Sewer: A pipe or conduit for carrying wastewater (sanitary sewer) or storm water (storm sewer).

Sidewalk: A paved, surfaced, or leveled area, usually parallel to and separate from the street, used as a pedestrian walkway.

Specification: A detailed instruction that designates the quality and quantity of materials and workmanship expected in the construction of streets and roads.

Standard Drawings: The drawings of structures, sanitary sewer lines, or devices commonly used and referred to on the Plans and in these Standards.

Standards: The Sanitary Sewer Design and Construction Standards for the Town of Hebron, Indiana as contained herein and all subsequent additions, deletions, or revisions.

Stopping Sight Distance: Distance required safely stop after a motorist recognizes an obstruction in the street or road. See INDOT Design Manual or AASHTO Green Book for specific design and measurement criteria.



DESIGN AND CONSTRUCTION STANDARDS

Storm Water Drainage System: All means, natural or manmade, used for conducting storm water to, through or from a drainage area.

Street, Private: Any street other than a public street.

Street, Public: All property dedicated or intended for public highway, freeway, or roadway purposes or subject to public easements.

Structure: Anything constructed or erected, the use of which requires permanent location on the ground or attached to something having a permanent location on the ground.

Substantial Completion: The time at which the Work (or a specified part thereof) has progressed to the point where, in the opinion of the Engineer, the Work (or a specified part thereof) is sufficiently complete, in accordance with the project plans and specifications, so that the Work (or a specified part thereof) can be utilized for the purposes for which it is intended. The terms “substantially complete” and “substantially completed” as applied to all or part of the Work refer to Substantial Completion thereof.

Subsurface Drain: A tile drain installed for the purpose of lowering the ground water table.

Temporary Cul-de-Sac: A turnaround located at the end of a stub street intended to be replaced when the adjoining area is developed and a through street connection is made.

Ten State Standards (Sewage Works): Recommended Standards for Sewage Works, latest edition, developed by the Committee of the Great Lakes – Upper Mississippi River Board of State Sanitary Engineers.

Thoroughfare Map: A legally adopted map that indicates the location of existing or proposed thoroughfares, including their street classification, alignment, and rights-of-way.

Thoroughfare Road: A Primary Arterial, Secondary Arterial, or Collector Road, as defined on the Thoroughfare Map.

Tile Drain: A perforated drain required parallel to a swale or ditch.

Town: The Town of Hebron, Indiana



DESIGN AND CONSTRUCTION STANDARDS

Town Engineer: The certified professional engineer or firm appointed by the Town to furnish engineering assistance in the administration of these Standards.

Travel Lane: Roadway lane designated for through travel movements.

Uniform Plumbing Code: The Uniform Plumbing Code adopted by the International Association of Plumbing and Mechanical Officials, current edition.

Watercourse: Any natural or manmade drainage way having a defined channel and banks and into which storm water runoff or floodwaters flow either regularly or intermittently.

Work: All the work to be done, in accordance with the approved Plans, Specifications, these Standards and permit conditions.

SECTION 4
GENERAL RULES AND REQUIREMENTS

<u>Section</u>	<u>Description</u>	<u>Page</u>
4.01	General.....	4-1
4.02	Design and Construction Approval for Development	4-1
	A. Requirements for Construction Permits	4-1
	B. Water Main Protection.....	4-1
	C. Technical Review Procedures.....	4-2
	D. Final Plan Approval	4-2
	E. Posting of Bond	4-3
	F. Pre-Construction Inspection	4-3
	G. Construction Inspection.....	4-4
	H. Requirements for Project Acceptance and Dedication.....	4-5
4.03	Safety.....	4-5
	A. Confined Space Access	4-5
	B. Hazard Communication Standard	4-5
	C. Excavation Safety Requirements	4-6
4.04	Building Sewers (Laterals).....	4-6
	A. Prohibition Against Clean Water Discharges	4-6
	B. Mandatory Inspection of Building Connections	4-6
	C. Building Sewer Responsibility	4-7
	D. Building Sewer Lateral Ownership	4-7



SECTION 4

GENERAL RULES AND REQUIREMENTS

4.01 General

This Section provides the general rules and policies for the construction of facilities as part of the sanitary sewers, including permit requirements and inspection.

4.02 Design and Construction Approval for Development

A. Requirements for Construction Permits

It shall be the responsibility of the Owner/Contractor to obtain valid Construction Permits for the construction or modification of any facility pertaining to the sanitary sewers from the Indiana Department of Environmental Management, Indiana Department of Transportation, or any other applicable regulatory agency.

A copy of all permits shall be filed with the Town upon receipt and prior to beginning any work.

B. Water Main Protection

Sewers and building services (laterals) shall be laid at least 10-feet horizontally from any existing or proposed water main. The distance shall be measured edge to edge. In cases where it is not practical to maintain a 10-foot separation, the appropriate reviewing agency may allow deviation on a case-by-case basis, if supported by data from the design engineer. Such deviation may allow installation of the sewer or service lateral closer to a water main, provided the water main is in a separate trench or on an undisturbed earth shelf located on one side of the sewer or service lateral and at an elevation so the bottom of the water main is at least 18-inches above the top of the sewer or service lateral.

If it is impossible to obtain proper horizontal and vertical separation as described above, both the water main and sewer or service lateral must



DESIGN AND CONSTRUCTION STANDARDS

be constructed of slip-on or mechanical joint pipe complying with public water supply design standards of the agency and be pressure tested to 150 psi to assure water tightness before backfilling.

Sewers and service laterals crossing water mains shall be laid to provide a minimum vertical distance of 18 inches between the outside of the water main and the outside of the sewer or lateral. This shall be the case where the water main is either above or below the sewer or lateral. The crossing shall be arranged so that the joints of the sewer or lateral will be equidistant and as far as possible from the water main joints. Where a water main crosses under a sewer or lateral, adequate structural support shall be provided for the sewer or lateral to maintain line and grade.

When it is impossible to obtain proper horizontal and vertical separation as stipulated above, one of the following methods must be specified:

- The sewer or lateral shall be designed and constructed equal to water pipe and shall be pressure-tested at 150 psi to assure water tightness prior to backfilling.
- Either the water main or the sewer or lateral line may be encased in a watertight carrier pipe which extends 10-feet on both sides of the crossing, measured perpendicular to the water main. The carrier pipe shall be of materials approved by the regulatory agency for use in water main construction.

C. Technical Review Procedures

The Owner/Contractor shall submit design plans for review and approval to the Town. The Town will then forward design plans to the Town's Engineer for review. All submittals shall go to the Town and not directly to the Town's Engineer. Revised plans and specifications shall be resubmitted to the Town for further review by the Town's Engineer, until final approval is granted.

D. Final Plan Approval

The Town Engineer shall issue final approval for all sanitary sewer projects, subject to final approval by the Town.



E. Posting of Bond

The Town requires the posting of a performance bond and a separate maintenance bond from a company licensed by the State of Indiana to provide such surety. Each bond shall be equal to 100% of the contract amount or an amount established by the Town to provide surety for the satisfactory completion of the improvements and shall name the Town of Hebron as a party who can enforce the obligations included. The duration of each bond shall be three (3) years, unless the Town determines a longer Bond is warranted due to factors such as the type or phasing of a project.

The Town may, as an alternative to the posting of such bond, accept other appropriate security such as properly conditioned irrevocable letter of credit which meets the same objective as the bonds described in this section, subject to approval of any other department or agency whose interests are protected by the same bonding requirement. The bank issuing the letter of credit must be a bank situated in Indiana and must be an FDIC insured institution.

If the surety on any bond furnished to the Town becomes a party to a supervision, liquidation, rehabilitation action pursuant to IC 27-9 et. seq. or its right to do business in the State of Indiana is terminated, it shall be required that, within 30-days thereafter, a substitute bond and surety be provided, both of which must be acceptable to the Town. Failure to obtain a substitute bond within the state time frame shall be cause for revocation or suspension of the project approval until such time that the bond is furnished to the Town.

F. Pre-Construction Inspection

The Owner/Contractor shall conduct a pre-construction, video taped, inspection of the construction site to serve as a permanent record of pre-construction conditions.

The product shall be high quality audio and video tape. The video portion shall present bright, sharp, clear pictures with accurate colors. The picture shall be free from distortion, tearing, rolls or other picture imperfection. The audio portion shall be proper volume, clarity and free of distortion. The audio commentary shall be precise and concise explanatory notes.



The recordings shall include coverage of all surface features located along the main route. The tape coverage shall include all existing cross streets, driveways, sidewalks, curbs, ditches, shrubbery or other structures located along the route.

G. Construction Inspection

Prior to issuance of the final project approval and commencement of any construction activities pertaining to the installation of any sanitary sewer project, the Owner/Contractor shall execute an Agreement with the Town, which will provide that:

- The Town may utilize its own personnel or contract for construction inspection service to insure that materials and workmanship meets the requirements of the approved plans and specifications.
- The Owner/Contractor shall be responsible for submitting and certifying air pressure or infiltration test results for all sewer pipe and deflection test results for all flexible and semi-rigid pipe, force main pressure tests, and all other testing as required.
- The Owner/Contractor shall reimburse the Town for the cost of such services which shall be determined at the time of execution of the Agreement, and verified by the Owner or his representative throughout construction.
- No action with regard to the acceptance of the construction and release of the improvement bond pursuant to this section shall be taken until the Owner/Contractor has reimbursed the Town in full for the inspection services.
- All construction of public works facilities intended for dedication to the Town shall be observed and certified pursuant to the Agreement.
- The Owner/Contractor shall furnish the Town with three (3) copies of the approved construction plans and specifications at the time the Agreement is executed.



H. Requirements for Project Acceptance and Dedication

Sanitary Sewer facilities will not be accepted until all documents, as required by the Town, are submitted to and approved by the Town Engineer and the Town, including the following:

- Required Maintenance Bond
- Recorded Easement Documents
- The completion of a final inspection which confirms that the project has been constructed and tested in accordance with the Town's Standards; and
- As-Built/Record Drawings and CCTV videos

4.03 Safety

Neither the Town nor its Engineer are responsible for safety on the job site. All codes, statutes, and regulations relating to safety on the job site shall be followed by the Owner, Developer, and Contractor. Direction by the Engineer and inspections by the Engineer are not designed to assure safety on the job, only that the sewer is built according to these standards and the drawings. The Contractor constructing the sewer shall advise each of his employees that the Town and the Town Engineer are not responsible for safety on the site.

A. Confined Space Access

For projects which include construction activities within "confined spaces" as defined by Title 29 CFR Part 1926.1202, the Contractor is hereby advised that he must fully comply with all pertinent requirements as delineated in this regulation and as interpreted by OSHA. The Contractor shall have and maintain all necessary safety and testing equipment at all times during the course of the construction activity.

B. Hazard Communication Standard

Pursuant to the Code of Federal Regulations, 29 CFR Part 1926, as may be amended, all Contractors, Subcontractors and materials suppliers on this Project shall provide access to all persons on the job site at all times, the Safety Data Sheets (SDSs) for all hazards of all chemicals per the Federal Regulations.



C. Excavation Safety Requirements

It shall be the duty and responsibility of the Contractor and all of his Subcontractors to be familiar and comply with all requirements of Public Law 91-596 29 USC, Sections 651 et. seq., the Occupational Safety and Health Act of 1970 (OSHA) and all amendments thereto, and to enforce and comply with all the provisions of the Act. In addition, and as required by Indiana State Law, HB 2071, Section 14 of IC 4-13.6-5-12, the Contractor and all of his Subcontractors shall comply with Subpart P of 29 CFR 1926 dated October 31, 1989 as may be amended.

4.04 Building Sewers (Laterals)

A. Prohibition Against Clean Water Discharges

No person shall discharge or cause to be discharged to any sanitary sewers either directly or indirectly:

- Storm water
- Surface water
- Ground water
- Roof runoff
- Subsurface drainage (gravity or pumped)
- Uncontaminated cooling water
- Unpolluted water
- Unpolluted industrial process water

B. Mandatory Inspection of Building Connections

It shall be the responsibility of the Owner to notify the Town that the sewer work is available for inspection. The Town will conduct inspections on all connections after not less than 24 hours notice has been given from 7:00 AM to 3:00 PM Monday through Friday except on observed Town holidays. The building sewer shall be fully exposed from the foundation to the point of connection with the public sewer.

The Town may take a minimum of two (2) construction “as-built” photographs for Town record prior to backfilling.

The Town and its authorized representative shall have the right of entry upon or through any premises for purpose of inspection of sewer work and any other construction activity performed on or associated with the



connection of the building sewer to the Town sewer, including inspection for clear water discharged into the sewer.

C. Building Sewer Responsibility

It shall be the responsibility of the property owner(s) whose property is benefited to provide for, install, and make private connections for the use of their premises to an existing public or building sewer. Further, it shall be the responsibility of the owner to make all necessary repairs, extensions, relocations, changes, or replacements thereof, and of any accessories thereto. These requirements may be altered, modified, or waived at the discretion of the Town when it is shown that compliance is not possible due to extenuating circumstances.

D. Building Sewer Lateral Ownership

The property owner is responsible for the maintenance and proper operation of the building sewer lateral from the sewer main to the point of use. Any blockages or tree root intrusions are the responsibility of the property owner to repair. All other issues with building sewer laterals will be reviewed by the Town on a case-by-case basis.

SECTION 5

GENERAL DESIGN STANDARDS FOR SANITARY SEWERS

<u>Section</u>	<u>Description</u>	<u>Page</u>
5.01	General.....	5-1
5.02	Sanitary Sewer Design Criteria.....	5-1
	A. General	5-1
	B. Residential Flows	5-1
	C. Commercial / Institutional Flows	5-1
	D. Industrial Flows	5-2
	E. Infiltration.....	5-2
	F. Pipe Capacities	5-2
	G. Pipe Diameter	5-2
	H. Minimum Slopes and Velocities	5-3
	I. Minimum Depth	5-3
	J. Building Sewers	5-3
	K. Manholes.....	5-4
	L. Outside Drop Connections	5-5
5.03	Lift Station and Force Main Design.....	5-5
	A. General	5-5
	B. Pump Sizing Criteria	5-6
	C. Force Main Sizing	5-6
	D. Lift Station Design	5-6
	E. Wet Well Sizing Criteria	5-6
	F. Lift Station Capacity	5-7
5.04	Easements	5-7
5.05	Drafting Standards.....	5-8



SECTION 5

GENERAL DESIGN STANDARDS FOR SANITARY SEWERS

5.01 General

The Town Council shall issue final approval for the installation of all sanitary sewer facilities. All facilities shall be designed and installed in accordance with these Standards, as well as, applicable State and Federal regulations.

5.02 Sanitary Sewer Design Criteria

A. General

All sanitary sewers shall be designed and constructed in accordance with IDEM and Ten States Recommended Standards for Wastewater Facilities.

All sanitary sewers shall be designed to carry the estimated flow from the area ultimately contributing to the respective service area of the sanitary sewer. The required capacity shall be established by the Town Engineer or at the Town's option by means of a study conducted by the Owner/Contractor or his authorized representative engineer. This study shall verify the capacity of downstream sewers to handle the proposed additional flow and the proposed connection point.

B. Residential Flows

For the purpose of design, the average family unit is considered to generate 310 gallons per day per single family home. Peak flows shall be as determined by Ten States Standards.

C. Commercial/Institutional Flows

The average daily flow for these facilities shall be based on Bulletin S.E. 13 from the Indiana State Board of Health, latest edition. These documents shall be used as a general guideline. The Town Engineer may allow modification of these guidelines based upon information submitted by the Owner/Contractor or developed by the Town Engineer.

Peak flow shall be determined by multiplying the average flow by a factor determined by the Owner/Contractor and approved by the Town Engineer.



D. Industrial Flows

For those industries which do not have any process wastewater discharge, flows shall be calculated as stated above in “Commercial/ Institutional Flows”. For industries which will have a process discharge, the Owner shall submit detailed flow estimates for each process, duration, and frequency.

Peak capacity shall be determined by multiplying the average discharge by a factor determined by the Owner/Contractor and approved by the Town Engineer.

E. Infiltration

Sanitary sewer design capacity must include an allowance to carry unavoidable amounts of groundwater infiltration or seepage in addition to the peak sanitary flows. Collector and trunk sewers shall be designed to include an allowance of 200 gallons per day per inch diameter mile of pipe.

F. Pipe Capacities

Collector sewers shall be classified as any sewer ranging between 8-inches and 12-inches in diameter. Peak design flow capacities shall be based upon the sewer flowing full without head.

Trunk or interceptor sewers shall be classified as any sewer 15-inches in diameter and larger.

Peak design flow capacities for trunk or interceptor sewers shall be based on full sewer flow, without head, using the design population density and appropriate land use determined by the Town and Town Engineer, and shall include an allowance for infiltration which will be reviewed on a case-by-case basis and is subject to the approval of the Town Engineer.

G. Pipe Diameter

The required diameter of gravity sewers shall be determined by Manning’s formula using a roughness coefficient, “n”, of 0.013 or required by the latest Ten States Standards.

The minimum pipe diameter for gravity sanitary sewers shall be 8-inches.



H. Minimum Slopes and Velocities

All sanitary collector, trunk and interceptor sewers shall be designed and constructed to provide a minimum velocity when flowing full of 2 feet per second. The slope of the pipe shall be such that these minimum velocity requirements are achieved. The minimum acceptable slopes for the design and construction of the sanitary sewers are as follows:

Pipe Size (Inches)	Minimum Slope (ft. per 100 ft., %)
8	0.40
10	0.28
12	0.22
15	0.15
18	0.12

These slopes may be modified by the approval of the Town and/or the Indiana Department of Environmental Management.

I. Minimum Depth

In general, sewers shall be sufficiently deep so as to receive sewage from the first floor of all places served by the sewers. No below ground floors may be directly connected via a gravity sewer to the collector sewer unless the floor is 1-foot above the rim of the upstream manhole. The sanitary sewers shall have a minimum cover of 4-feet unless waived by the Engineer. The pipe shall have a minimum cover of 3-feet under small streams or ditch crossings. The developer shall construct the sanitary sewer at reasonable depths to avoid interference with other utilities or drainage structures.

J. Building Sewers (Laterals)

Building sewers shall conform to the latest edition of the Uniform Plumbing Code, these Standards, and Town Ordinances. No more than one (1) building will be permitted to connect to a building sewer. Sewers with more than one (1) connection must be constructed as a sanitary sewer in a dedicated easement with a minimum sewer diameter of 8-inches and manholes.

The building sewer shall connect to the public sewer at a mainline fitting. In situations where this requirement may not be possible, the Town will allow for connection of the lateral directly to a manhole structure providing



DESIGN AND CONSTRUCTION STANDARDS

the connection occurs at the manhole invert. Under these circumstances, the manhole base shall be pre-formed with a gasketed connection for the lateral line. The invert of the manhole shall also have a formed benchwall at the flow line to accept the lateral sewer connection. Laterals from two separate buildings may be installed parallel in the same trench but shall be a minimum of 4-feet apart and a minimum of 2-feet off the property line.

All single-family, multi-family, commercial, institutional, and industrial dwellings will require 6-inch diameter laterals. Building sewers shall have a 6-inch wye cleanout located within 3-feet of the building's exterior wall and extended to grade. The cleanout shall be fitted with a pop-off lid and shall be constructed such that it is located below the floor level serviced by the gravity sewer to serve as a relief point in the event the municipal sanitary sewer backs up. Industrial buildings shall have a suitable control manhole for observation, sampling, and measurement of the waste stream located prior to the connection to the sanitary sewer, as required by the Town Engineer.

Cleanouts installed under concrete or asphalt paving shall be made accessible by yard boxes or extended flush with paving with approved materials and be adequately protected.

Building sewers installed for future connections shall be terminated at the right-of-way or easement and plugged to ensure 100% water tightness. A 5/8-inch steel rod shall be installed so that it is flush with finished grade.

All new building sewers shall be provided with tracer wire and location tape from the mainline sewer connection to the edge of right-of-way or easement as described in Sections 6 and 8.

If approved by the Town, a service may be cut into an existing public sewer using a mainline fitting and Fernco coupling or a saddle connection.

K. Manholes

Manholes shall be installed at the end of each line. Cleanouts will not be acceptable. Manholes shall also be installed at all changes in grade, size, materials, or alignment and at all sewer intersections. The interval between manholes shall not be greater than 400-feet unless a greater distance is approved by the Town.

The minimum inside diameter of manholes shall be 48-inches.



DESIGN AND CONSTRUCTION STANDARDS

Flow channels shall be shaped and formed in each manhole to provide a smooth transition of flow from all inlets to the outlet. The bench wall shall be formed to the crown of the inlet and outlet pipes to form a “U” as shown in the Standard Details included in these Standards.

At changes in sewer alignment and/or sizes, the energy gradient elevation shall not increase. This shall be accomplished by keeping the “0.8 diameter” of the crown elevation continuous where possible for changes in sewer sizes.

Manholes proposed to be installed in unpaved areas shall be designed and constructed such that the top of the casting is flush with the finished grade to prevent ponding of water over the casting. Positive drainage away from the manhole shall be provided.

Manholes receiving discharge from force mains in which the discharge is more than 12-inches above the manhole invert shall have an internal drop connection. New and existing manholes which have force main discharge lines shall have an internal coating to prevent corrosion. Internal coating shall be by Spectra-Tech, or equal.

L. Outside Drop Connections

Outside drop pipe connections shall be provided for all sanitary sewers entering a manhole at an elevation greater than 24-inches above the invert of the manhole.

In areas where future residential, commercial, institutional, and/or industrial growth can occur, the Town shall determine which new manholes 15-feet deep or deeper shall be equipped with outside drop connections of a size and at an elevation to be determined by the Town Engineer at the time of design to allow for future connections at these points. The drops shall extend from the base to within 10-feet of the final graded surface elevation.

5.03 Lift Station and Force Main Design Criteria

A. General

All lift stations shall be designed and constructed in accordance with IDEM and Ten States Standards. All design criteria and calculations shall be submitted to the Town Engineer for approval.



No lift station shall be approved for a project unless a 50-year life cycle analysis is submitted to the Town to demonstrate that it will be more cost effective for the Town in lieu of constructing a deeper gravity sewer.

B. Pump Sizing Criteria

Lift Station pumps shall be provided to accommodate peak hourly flow with the largest pump out of service. A minimum of two (2) pumps shall be provided at each lift station.

C. Force Main Sizing Criteria

Force mains shall be designed to maintain a minimum of 2-feet per second in order to avoid solids deposition in the pipe. Minimum force main size shall be 4-inches in diameter unless specifically authorized by the Town Engineer.

D. Lift Station Design

All lift stations shall be wet well/valve vault design utilizing submersible pumps in the wet well with a separate valve vault. Provisions for draining the valve vault into the wet well shall be made.

Provisions shall be made for connection to the Town's portable generators in the event of a power failure.

E. Wet Well Sizing Criteria

The wet well storage below the lowest inlet shall be a minimum of 5-feet and shall also meet the following criteria:

- OFF level to be set at the pump manufacturer's recommended level but no less than 1-foot from the bottom of the wet well.
- The distance between the OFF level and the lead pump ON level shall be set to provide storage capacity in gallons equal to:

$$\frac{15 \times \text{Rated Pump GPM}}{4}$$

(i.e. 15 minute cycle minimum)



- The lag pump ON level shall be set a minimum of 6-inches above the lead pump ON level.
- The high-water alarm shall be set a minimum of 6-inches above the lag pump ON level.
- All level settings shall be set a minimum of 6-inches below the lowest invert.

F. Lift Station Capacity

All lift stations will be designed with a minimum capacity of 100-gallons per minute (gpm) to meet IDEM's requirement of maintaining 2-feet per second (fps) in force mains. This includes the wet well size, piping, electrical equipment, etc.

5.04 Easements

All sanitary sewer lines and lift stations not installed in public rights-of-way shall be protected by dedicated Sanitary Sewer Easements.

The minimum sewer easements shall be 15-feet wide for force mains; 20-feet wide for sanitary sewers up to 15-feet deep; 25-feet wide for sanitary sewers between 15-feet deep and 22-feet deep; and 30-feet wide for sewers greater than 22-feet deep.

All sewers shall be centered in the easement unless a water main is also present. In that case, a minimum of 10-feet separation must be maintained between the water line and the sewer line, and additional easement widths may be required as determined by the Town Engineer.

A minimum 50-feet by 50-feet easement shall be provided for all submersible lift stations.

Regulated drain limits shall be shown on all plans.

The easements shall be exclusively under the discretion and control of the Town. Ingress and egress shall be available to the Town's crew at all times. No utility companies are allowed to use the easements for installation of their utility lines without the expressed written permission of the Town. All plans shall clearly identify the easement and the location of all other proposed utilities. The horizontal and vertical plans shall identify all utilities proposed to cross the easement.



5.05 Drafting Standards

All plans and specifications are to be certified and dated by a professional engineer of the State of Indiana.

Include all detail sheets and specification sheets as applicable.

Design plans shall be 24-inch by 36-inch.

The scale for plan and profile sheets shall not exceed 1"=30' Horizontal and 1"=5' Vertical.

SECTION 6

MATERIALS FOR SANITARY SEWERS

<u>Section</u>	<u>Description</u>	<u>Page</u>
6.01	General.....	6-1
6.02	Gravity Sanitary Sewer.....	6-1
	A. General	6-1
	B. Sanitary Sewer Pipe Materials	6-1
	C. Depth Restrictions on Pipe Materials	6-2
6.03	Sanitary Sewer Force Mains	6-2
	A. General	6-2
	B. Force Main Materials.....	6-2
	C. Locator Tape and Wire.....	6-5
	D. Air/Vacuum Relief Valves.....	6-5
6.04	Building Services/Service Laterals	6-6
6.05	Sanitary Sewer Manholes / Wet Wells and Valve Vaults	6-6
	A. Precast Manholes	6-6
	B. Manhole Steps	6-7
	C. Adjusting Rings	6-7
	D. Sewer Pipe to Manhole Connections	6-7
	E. Castings	6-7
	F. Extruded Preformed Gasket Material.....	6-8



SECTION 6

MATERIALS FOR SANITARY SEWERS

6.01 General

This section provides a description of the materials acceptable for the construction of sanitary sewer facilities. Use of other materials which are not specified herein shall only be permitted with the written approval by the Town and Town Engineer.

6.02 Gravity Sanitary Sewer

A. General

The following materials are acceptable for gravity sanitary sewers:

- Polyvinyl Chloride (PVC) Pipe
- Ductile Iron Pipe (DIP)

All pipe shall be the bell and spigot type with elastomeric seal joints.

All pipe shall be required to withstand testing requirements as described in other Sections of these Standards.

B. Sanitary Sewer Pipe Materials

1. PVC Pipe

All gravity sewer pipe shall be solid-wall Polyvinyl Chloride (PVC), SDR 35 conforming to ASTM D 3034. Joints shall be bell and spigot type with elastomeric seals per ASTM D3212, with gaskets conforming to ASTM F-477.

Mechanical Plugs shall be wedge type plugs with rubber "O" rings to provide an air tight fitting.

2. Ductile Iron Pipe

Pipe shall be ductile iron gravity sewer pipe conforming to ASTM A-746. Minimum thickness class shall be Class 50. The outside



coating shall be a bituminous coating approximately 1 mil thick. The interior lining shall be cement mortar in accordance with ANSI A21.4.

Joints shall be either push-on or mechanical. Fittings for force mains shall be mechanical joint cast or ductile iron conforming to ANSI A21.10.

C. Depth Restrictions on Pipe Materials

The depth limitations for the installation of the different pipe materials, unless a variance is approved by the Engineer, shall be as follows:

- PVC SDR 35 – 3-feet to 20-feet
- PVC SDR 26 – 3-feet to 28-feet
- DIP – 3-feet to 28-feet

With each depth range, special pipe bedding requirements may be requested by the Engineer to insure adequate pipe support.

6.03 Sanitary Sewer Force Mains

A. General

The following materials are acceptable for sanitary sewer force mains:

- Polyvinyl Chloride (PVC) Pipe
- Ductile Iron (DI) Pipe
- High Density Polyethylene (HDPE) Pipe

B. Force Main Materials

1. Polyvinyl Chloride (PVC) Force Main

Pipe shall conform to ANSI/ASTM D 2241 and have SDR 21. Pipe materials shall conform to ASTM D 1784, Type 1, Grade 1, 2,000 psi design stress. Pipe joints shall be single gasket bell and spigot type, the bells being formed integrally with the pipe.

Fittings shall be mechanical joint iron or ductile iron conforming to ANSI A21.10/AWWA C 110 and ANSI A21.11/AWWA C 111. Restrained joints may be used instead of mechanical joints and thrust blocking and shall be Loc-Tyte, Loc-Fast or approved equal.



2. Ductile Iron (DI) Force Main

Pipe shall be centrifugally cast in metal or sandlined molds and shall conform to ANSI A21.51/AWWA C 151. Minimum thickness class shall be Class 50 for all sizes. Pipe joints shall be push-on type and conform to ANSI A21.11/AWWA C 111 unless otherwise noted on the Plans. Each length of pipe shall be marked to show manufacturer's name or trademark, pipe class, and year of manufacture conforming to ANSI A 21.51/AWWA C 151.

Fittings - shall be mechanical joint and iron or ductile iron conforming to ANSI A 21.10/AWWA C 110 and ANSI A21.11/AWWA C 111. Restrained joints may be used instead of mechanical joints and thrust blocking and shall be Lok-Tyte, Loc-Fast, or equal.

Coatings - all pipe and fittings shall have a standard thickness cement mortar lining as specified in ANSI A 21.4/AWWA C 104 and an outside coating as specified in ANSI A 21.51/AWWA C 151.

Gaskets - for mechanical joints and push-on joints shall conform to ANSI A21.11/AWWA C 111.

3. High Density Polyethylene (HDPE) Force Main

Materials used for the manufacture of polyethylene pipe and fittings shall be extra high molecular weight, high density PE 3408 polyethylene resin. Polyethylene pipe shall meet the requirements of ASTM D3034/F714. Cell classification shall be 345444C per ASTM D3350. Design and manufacturer pipe for working pressure of 80 psi and 120 psi surge pressure and a depth of cover indicated on the Plans and specified in this section.

Polyethylene pipe shall have DR (Dimension Ratio) 21 and a nominal IPS (Iron Pipe Size) outside diameter unless otherwise specified. If pipe is to be installed with directional drilling, DR 11 pipe shall be required.

Fittings shall be manufactured in accordance with ASTM D3261 and shall be manufactured by injection molding, a combination of extrusion and machining, or fabrication from HDPE pipe listed in this specification. Fittings shall be manufactured by the same manufacturer as the pipe to which fusion bonding is intended, using identical materials. Fittings shall be manufactured to meet the same pressure rating as the pipe with an included 2:1 safety factor. The



DESIGN AND CONSTRUCTION STANDARDS

pipe DR (Dimension Ratio) shall be used to determine the fitting pressure rating requirements. Fitting shall be manufactured in facilities designed for that purpose. Field-fabricated fitting shall not be allowed.

Branch Saddle Reducing Tees shall be used to connect Air Release Valves to the force mains. Saddles shall be main line size by 4-inch with 4-inch flange adapter and back-up ring, and 4-inch x 2-inch National Pipe Thread Tapered (NPT) companion flange.

Flange backup rings shall be of the type and pressure rating shown on the piping spool drawings. Ductile iron backup rings shall be of the convoluted type, fabricated from ductile iron per ASTM A536, grade range 60/40/18 to 65/45/12. Ductile iron flange backup ring bolting dimension shall conform with ANSI B16.5 Class 150.

Backup rings shall be finished as cast with flash removed from all edges and bolt holes to the specified dimensions. Additional finish requirements, if any, shall be as noted on the piping spool drawings and in accordance with the following:

- Epoxy coated, with Bitumastic 300M High Build Coal Tar Epoxy per manufacturer's recommendations.
- Gaskets shall be of the type and thickness shown on the piping spool drawings. Gasket materials shall be compatible with the service of the piping system. Asbestos gaskets will not be allowed.

Piping joints other than those shown as flanged or otherwise mechanically connected shall be butt-fusion bonded in accordance with a written bonding procedure specification (BPS) as required by ANSI/ASME B31.3, Chapter VII, paragraph A-328. BPS shall include cutting and facing requirements and shall utilize a data logger.

Materials to be fusion bonded shall be from the same manufacturer. Bonders and bonding operators shall be qualified in the use of the BPS as required by ANSI/ASME B31.3, Chapter VII, paragraph A-328. Qualification records certifying that bonders and bonding operators employed to complete fusion bonding are qualified in the BPS shall be submitted prior to commencement of fusion bonding work.

Bonding equipment specified in the BPS shall be in proper operating condition. Equipment heater performance shall be tested and



DESIGN AND CONSTRUCTION STANDARDS

certified prior to use for fusion bonding. Bonders and bonding operators shall be qualified for the specific bonding equipment utilized in the fusion bonding work.

The joining method shall be performed in strict accordance with the pipe manufacturer's requirements. The butt fusion equipment used in the jointing procedure shall be capable of meeting all conditions required by the pipe manufacturer, including temperature, alignment and fusion pressure. Heat fusion joining shall be 100% efficient offering a joint weld strength at least equal to the tensile strength of the pipe. Each butt fusion joint shall be logged electronically by the butt fusion unit, for quality control, by such equipment as The Data Logger manufactured by McElroy Manufacturing, Inc. Logged fusion joints shall be stored in the Data Logger unit, such that it can be downloaded and printed weekly for submittal to the Town.

C. Locator Tape and Wire

Locator wire for force mains shall be #12 standard copper wire with thermoplastic insulation and capable of carrying 600 volts.

Marking tape shall be metallic type tape such as Terra Tape Detectable as manufactured by Ruf Industries, Inc., or approved equal. Tape shall be marked with "Caution Sewer Line Buried Below".

D. Air/Vacuum Relief Valves

The design of sanitary sewer force mains shall preclude the need for air / vacuum relief valves by eliminating high points. If high points cannot be eliminated, an air relief valve shall be installed at each point. Air valves shall be properly sized for each application. Each valve shall be installed in a precast concrete structure.

Sewage Air Release and Air Vacuum Valves shall have cast iron body and cover with an NPT inlet and NPT outlet, properly sized per each application, and having stainless steel float and float guide. Valve shall be as manufactured by Val-Matic Valve and Manufacturing Co., Apco, or approved equal.

Start-up/checkout services shall be provided for each air valve installed by a qualified manufacturer's representative to check the completed installation, place the air valves in and check the operation, and instruct the Town's personnel in the operation and maintenance procedures. The



purpose of these services is to demonstrate to the Town's satisfaction that the air valves have been properly selected and installed and will satisfactorily perform the functions for which they are intended. Provide three (3) sets of Operation and Maintenance (O&M) manuals for each type of air valve installed.

6.04 Building Sewers / Service Laterals

Building sewers or services shall be SDR 35, bell and spigot type PVC pipe. Joints shall be gasket push-on, compression type conforming to ASTM D3212. Gaskets shall conform to ASTM F477. Factory made wye connections shall be provided at the connection with the municipal sewer line and shall be made in such a manner as will provide strength and watertightness at least equal to the class of the adjacent main line pipe to which they are jointed and shall conform to all other requirements specified for pipe corresponding class and internal diameter. Joints shall be of the same type as used on the adjoining pipe.

Where allowed, saddle connections to facilitate lateral connections to the existing sanitary sewer shall conform to ASTM D3034. Fabricated branches for wyes and tees shall be securely attached to the wall of the pipe in a watertight manner and shall be flush with the inside surface of the pipe. When repairing or re-establishing a service lateral connection Fernco couplings shall be used with accompanying stainless steel shear rings.

Where required on a service lateral, a cleanout shall be provided (6-inch diameter minimum) made of the same material as the main line pipe. Said cleanout shall include a watertight, detachable lid and conform to the Service Connection Detail.

Tracer wire and location tape shall be installed for building sewers from the mainline sewer to the edge of right-of-way or easement. Refer to Section 6.03.C for material requirements.

6.05 Sanitary Sewer Manholes / Wet Wells and Valve Vaults

A. Precast Manholes

Manholes shall be precast concrete manhole risers with 8-inch precast concrete base and shall meet the requirements of ASTM C-478. Precast concrete manhole cones shall be of eccentric cone type and meet the requirements of ASTM C-478. Manhole risers shall be minimum 48-



inches inner diameter. Eccentric cone sections shall have a 24-inch opening.

Joints for manhole sections shall have a flexible butyl rubber joint gasket conforming to ASTM C-443.

B. Manhole Steps

All new manholes shall be fabricated with no steps. For any existing manholes being rehabilitated as part of a project, all existing steps shall be removed.

C. Adjusting Rings

Where one (1) solid riser or barrel section cannot be used, final adjustments in elevation of the frame and cover shall only be accomplished by the use of precast concrete adjusting rings conforming to ASTM C-478.

Rings shall be of a nominal thickness of not less than 4-inches. No more than 12-inches total of adjusting rings shall be allowed for adjustment of the manhole frame and cover to the required elevation.

D. Sewer Pipe to Manhole Connections

Resilient connections shall be provided for all pipe penetrations. For resilient boots, each manhole shall be core-drilled at the proper location where the pipe enters the manhole. A flexible neoprene molded boot shall be installed to secure the pipe. The boot shall be Kor-N-Seal as manufactured by National Pollution Control Systems, Inc. For resilient gaskets, each gasket shall be cast into the manhole at the proper location during manufacturing and shall be A-Lok or approved equal.

E. Castings

Manhole frames and lids shall have machined horizontal and vertical bearing surfaces. Watertight frames and lids for sanitary sewers shall have a grooved rubber gasket with concealed pick holes and shall be as manufactured by East Jordan Iron Works, No. 1022-1, or approved equal. All frames and lids shall be products of one manufacturer. Bolt-down lids shall be provided on manholes located in floodplains or areas susceptible to flooding or ponding water.



The frame shall be anchored to the cone section of the manhole with three (3) stainless steel rods or expansion bolts through the riser rings (if provided). Each lid shall have 2-inch letters indicating "SANITARY SEWER".

F. Extrudable Preformed Gasket Material

A nominal 1/2-inch size butyl rubber base gasket material, conforming to AASHTO M-198 and Federal Specification SS-S-210A, shall be used for adjusting ring grooves; between adjusting ring and cone; between cone and casting; and between adjusting ring and casting. The gasket material shall be as manufactured by Hamilton Kent-Seal.

SECTION 7

SANITARY SEWER LIFT STATIONS

<u>Section</u>	<u>Description</u>	<u>Page</u>
7.01	General.....	7-1
7.02	General Requirements.....	7-1
	A. General	7-1
	B. Pump Size Criteria	7-1
	C. Force Main Sizing Criteria	7-1
	D. Lift Station Design	7-1
	E. Wet Well Sizing Criteria	7-2
	F. Lift Station Capacity	7-2
7.03	General Requirements.....	7-2
7.04	Operating Conditions	7-4
7.05	Product	7-4
7.06	Pump Design	7-4
7.07	Pump Construction.....	7-5
	A. Casing and Back Pull-Out Adapter Plate	7-5
	B. Impeller	7-5
	C. Cutter Bar	7-6
	D. Cutter Nut.....	7-6
	E. Upper Cutter.....	7-6
	F. Shafting	7-6
	G. Submersible Electric Motor	7-6
	H. Lower Mechanical Seal	7-7
	I. Stainless Steel Nameplates	7-7
	J. Surface Preparation	7-7
7.08	Concrete Wet Well and Valve Vault.....	7-7

7.09	Piping and Valves	7-7
	A. Wet Well and Valve Vault Piping.....	7-7
	B. Plug Valves	7-8
	C. Check Valves	7-9
7.10	Accessories	7-9
	A. Slide Rail System	7-9
	B. Access Hatches	7-10
	C. Portable Hoist.....	7-11
	D. Cable Holder	7-11
7.11	Control Panel.....	7-11
7.12	Level/Pump Control System	7-14
7.13	Operation of System.....	7-15
7.14	Electrical Components	7-15
7.15	Station Warranty	7-16



SECTION 7

SANITARY LIFT STATIONS

7.01 General

This section pertains to the requirement for sanitary sewer lift stations designed and constructed by an Owner / Contractor. The Town shall review and approve the use of any lift station. The Owner must show that it is not physically possible or economically feasible to provide gravity service into a public sewer.

7.02 Lift Station and Force Main Design Criteria

A. General

All lift stations shall be designed and constructed in accordance with IDEM and Ten States Standards. All design criteria and calculations shall be submitted to the Town Engineer for approval.

No lift station shall be approved for a project unless a 50-year life cycle analysis is submitted to the Town to demonstrate that it will be more cost effective for the Town in lieu of constructing a deeper gravity sewer.

B. Pump Sizing Criteria

Lift Station pumps shall be provided to accommodate peak hourly flow with the largest pump out of service. A minimum of two (2) pumps shall be provided at each lift station.

C. Force Main Sizing Criteria

Force mains shall be designed to maintain a minimum of 2 fps in order to avoid solids deposition in the pipe. Minimum force main size shall be 4-inches in diameter unless specifically authorized by the Town Engineer.

D. Lift Station Design

All lift stations shall be wet well/valve vault design utilizing submersible pumps in the wet well with a separate valve vault. Provisions for draining the valve vault into the wet well shall be made.



DESIGN AND CONSTRUCTION STANDARDS

Provisions shall be made for connection to the Town's portable generators in the event of a power failure.

E. Wet Well Sizing Criteria

The wet well storage below the lowest inlet shall be a minimum of 5-feet and shall also meet the following criteria:

- OFF level to be set at the pump manufacturer's recommended level but no less than 1-foot from the bottom of the wet well.
- The distance between the OFF level and the lead pump ON level shall be set to provide storage capacity in gallons equal to:

$$\frac{15 \times \text{Rated Pump GPM}}{4}$$

(i.e. 15 minute cycle minimum)

- The lag pump ON level shall be set a minimum of 6-inches above the lead pump ON level.
- The high-water alarm shall be set a minimum of 6-inches above the lag pump ON level.
- All level settings shall be set a minimum of 6-inches below the lowest invert.

F. Lift Station Capacity

All lift stations will be designed with a minimum capacity of 100 gpm to meet IDEM's requirement of maintaining 2 fps in force mains. This includes the wet well size, piping, electrical equipment, etc.

7.03 General Requirements

All of the mechanical and control equipment shall be an integral package supplied by the pump manufacturer with local representation so as to provide undivided responsibility.

The Contractor shall submit to the Town Engineer for review and approval two (2) sets of shop drawings, detailed specifications, pump warranty and performance characteristics for all of the equipment and fixtures to be furnished



DESIGN AND CONSTRUCTION STANDARDS

and installed. The shop drawings and equipment data shall be submitted with a cover letter and Contractor's stamp of approval, indicating he has reviewed, checked and approved the data submitted. The Town Engineer will review the submittal and render a decision in writing as to the acceptability of the equipment.

The Contractor shall provide the services of a factory service engineer to inspect the installation and alignment of all equipment and materials provided under this section. Upon completion of the installation and alignment, the service engineer shall certify to the Town, in writing, that the equipment furnished has been installed and aligned in accordance with all requirements, recommendations, and advisory instructions of the equipment manufacturer.

After the installation and alignment is complete, the factory service engineer shall operate the equipment for such a period as to assure the proper functioning of the same. All auxiliary equipment shall be operated to demonstrate that it is functioning properly. Any adjustments deemed necessary to place the equipment in proper operating condition will be made. Such adjustments shall be made at the Contractor's expense. The Lift Station Inspection Form included in Section 2 shall be completed, the drawdown pump tests shall be performed, and the results submitted to the Town using the forms included in these Standards.

The pump supplier shall have full-time service personnel and repair facilities at his place of business to be eligible as a pump supplier to the Town.

The Contractor shall supply the services of a factory service engineer for one (1) day in addition to the time described above to provide on-site instruction to the Owner's personnel in operation, routine maintenance, and "trouble shooting" for each piece of equipment furnished under this section.

The manufacturer shall provide three (3) bound copies of a manual fully explaining the operation, routine maintenance, and "trouble shooting" for all the equipment provided in this section. The manual shall include copies of all approved shop drawings with all required revisions. This manual must be submitted to the Town for approval prior to acceptance.

Any exceptions to this Standard or associated approved Plans shall be submitted in writing and clearly stated. The exceptions must be approved by the Town prior to proceeding with the work.

All components of the lift station that are exposed to weather shall be constructed of material that is resistant to corrosion and will not require surface protection throughout the expected life of the lift station. In general, these materials are



DESIGN AND CONSTRUCTION STANDARDS

stainless steel, aluminum, fiberglass reinforced polyester (FRP), and ultraviolet stabilized PVC.

All valves and piping coming in contact with sewage or connected to the pump or valve chambers shall be coated as follows:

- Primer – Aromatic Urethane Zinc-Rich 2.5 – 3.5 mil
- Field Coats – Aliphatic Acrylic Polyurethane 2 coats at 2 – 4 mil per coat

Inlet piping shall be located such that the sewage discharging into the wet well does not fall directly onto one or both of the submersible pumps.

7.04 Operating Conditions

Prior to installation, the Contractor shall submit the following information for each pump to the Town Engineer for review and approval. Preference for high efficiency pumps will be considered.

- Pump capacity in gallons per minute
- Total dynamic head (TDH) and Operating RPM
- Motor Horsepower
- Motor RPM
- Motor voltage, phase, and cycle
- Make and model number of the pump
- Pump curves for the pumps to be provided.

7.05 Product

The Contractor shall furnish complete, a submersible lift station, consisting of submersible chopper pumps, motors, piping, valves reinforced concrete wet well, electrical controls, guide systems, and all other appurtenances as specified in these Standards.

All pumping units shall meet the requirements of Hydraulic Institute (HI) standards.

The pumps provided shall be approved by the Town and shall be provided by a Town-approved local supplier.

7.06 Pump Design

The submersible chopper pumps shall be specifically designed to pump waste solids at heavy consistencies without plugging or dewatering of the solids.



DESIGN AND CONSTRUCTION STANDARDS

Materials shall be chopped/macerated and conditioned by the pump as an integral part of the pumping action. The pump must have demonstrated the ability to chop through and pump high concentrations of solids such as plastics, heavy rags, grease and hair balls, wood, paper products and stringy materials without plugging, both in tests and field applications. The pumps shall have the ability to pass a 3-inch diameter spherical solid.

Each pump shall be furnished and installed with the necessary length of new submersible power and control cable compatible with the pumps furnished and suitable for submersible pump applications. The power cable shall be sized according to NEC and CSA. The cable shall not be spliced.

Each pump shall be automatically and firmly connected to the discharge connection elbow guided by two (2) stainless steel guide bars extending from the top of the station to the discharge connection. There shall be no need for personnel to enter the wet well. The pump discharge elbow shall be cast iron with mounting feet and 150-pound flange.

7.07 Pump Construction

A. Casing and Back Pull-Out Adapter Plate

The pump casing shall be of semi-concentric design, with the first half of the circumference being cylindrical beginning after the pump outlet, and the remaining circumference spiraling outward to the 150-pound flanged centerline discharge. Back pull-out adapter plate shall allow removal of pump components from above the casing, and allow external adjustment of impeller-to-cutter bar clearance. Casing and adapter plate shall be ASTM A536 ductile cast iron with all water passages to be smooth, and free from blowholes and imperfections for good flow characteristics.

B. Impeller

The pump impeller shall be the semi-open type with pump out valves to reduce seal area pressure and to draw lubricant down from the reservoir should seal leakage occur. Chopping/maceration of materials shall be accomplished by the action of the cupped and sharpened leading edges of the impeller blades moving across the cutter bar at the intake openings with a set clearance between the impeller and cutter bar of 0.010-inches to 0.015-inches. Impeller shall be ASTM A148 cast alloy steel heat treated to a minimum Rockwell C 60 and dynamically balanced. The impeller shall be keyed to the shaft and shall have no axial adjustments or set screws required.



C. Cutter Bar

The cutter bar shall be recessed into the pump bowl and shall extend diametrically across the entire suction opening. The cutter bar shall be constructed of T1 alloy steel plate and heat treated to a minimum Rockwell C 60.

D. Cutter Nut

The impeller shall be secured to the shaft using a special cutter nut designed to cut stringy materials and prevent binding. The cutter nut shall be ASTM A148 cast alloy steel heat treated to a minimum Rockwell C 60.

E. Upper Cutter

The upper cutter shall be threaded into the back pull-out adapter plate above the impeller designed to cut against the pump-out vanes and the impeller hub, reducing and removing stringy materials from the mechanical seal area. Upper cutter shall be ASTM A148 cast alloy steel heat treated to a minimum Rockwell C 60.

F. Shafting

Pump shafting shall be AISI 4140 heat treated. The pump shaft shall directly couple to the motor shaft with a bolt and keyway.

G. Submersible Electric Motor

The submersible electric motor shall be U/L LISTED EXPLOSION PROOF for Class 1, Group D, Division 1, hazardous locations, rated at 240 or 480 Volts, 60 Hertz and 3 phase, with a 1.15 service factor and Class B insulation system with Class F materials. The motor shall be equipped with tandem mechanical seals in an oil bath and dual moisture sensing probes. The motor shall include two (2) normally closed automatic resetting thermostats connected in series and imbedded in adjoining phases. Motor frame shall be cast iron and all hardware and shaft shall be stainless steel.



H. Lower Mechanical Seal

The lower mechanical seal shall be either Alloy 20 welded metal bellows type with silicon carbide faces or 316 stainless steel pusher type with tungsten carbide faces (depending on the motor frame size).

I. Stainless Steel Nameplates

Nameplates shall be attached to the pump and drive motor giving the manufacturer's model and serial number, rated capacity, head, speed, and all other pertinent data. The nameplates shall be stainless steel.

J. Surface Preparation

SSPC-SP5 white metal sandblast, prime coat, and finish coat all surfaces with a total 4 MDFT of stainless-steel pigment epoxy.

7.08 Concrete Wet Well and Valve Vault

The Contractor shall furnish and install a monolithic concrete or precast manhole type wet well. The pumps and all other related equipment shall be installed and/or mounted as described herein or as ordered by the manufacturer(s).

A concrete valve vault shall be furnished and installed to house the valves and appurtenances. Provide an aluminum access ladder in the valve vault.

Precast manhole sections shall conform to the requirements as set forth in ASTM Specification C478. Wet well and valve vault shall be constructed in the same manner as described in Section 5 of these Standards.

7.09 Piping and Valves

A. Wet Well and Valve Vault Piping

Piping in the wet well through the valve vault to the connection to the force main shall be ductile iron. Ductile iron pipe shall meet the requirements of ANSI A21.51/AWWA C151 and shall be designed and manufactured for a working pressure of 150 psi plus 100 psi surge and a safety factor of 2. Minimum pressure class shall be 150.



DESIGN AND CONSTRUCTION STANDARDS

Gaskets for flange joints on exposed pipe shall meet ANSI/AWWA C110, full face rubber or other material approved by the engineer and must have minimum 1/8-inch thickness. Nuts and bolts shall conform to ANSI/AWWA C110 and be zinc-coated alloy steel.

Pipe joints for buried piping shall be push-on type. Joints shall meet the requirements of ANSI/AWWA A21.2/C111. Restrained joints shall be wedge-action retainers for mechanical joint fittings or field-lock wedge-action gaskets for push-on joints.

Fittings shall be ductile iron. Fittings shall meet the requirements of ANSI/AWWA C110. Design and manufacture fittings for a pressure rating of 150 psi. Fittings shall have mechanical joints or restrained push-on joints. Joints shall meet the requirements of ANSI/AWWA A21.1/C111. Thrust blocking or restrained joints are required at fitting locations.

B. Plug Valves

Eccentric Plug Valves for wastewater service shall be non-lubricated with a resilient sealing surface. Valves shall have screwed, flanged, or mechanical joint ends conforming to ANSI/AWWA C110 requirements. Port areas shall be at least 80% of full pipe area. Valves shall have permanently lubricated stainless steel slave-type bearings, or other lubricated type bearings, in the upper and lower stem journals. Valve seats shall be corrosion resistant having a high nickel content.

Bonnet shaft seals shall be capable of being replaced while line and valve remain in service, thereby eliminating the need to take lift stations out of service. All exposed nuts, bolts, springs, and washers shall be stainless steel. Means of actuation shall be by operating nut with a hand lever. Provide one lever for each valve vault.

The valves shall be capable of providing drop-tight shutoff with flow in either direction up to the valve's rated operating pressure. Flanged valves shall be faced and drilled to ANSI B.16.1, Class 125 standard. Flanges of valves through 12-inches shall have face-to-face dimensions of ANSI/AWWA standard gate valves.

The plug face material shall be nitrile-butadiene, Neoprene, or as approved by the Town.

Each actuator or operator shall be capable of seating and unseating the valve and have a maximum torque 50 foot-pounds on operating nuts.



Valves shall be DeZurik, Series 100, Val-Matic, Cam-Centric, or equal.

C. Check Valves

Rubber flapper check valves for wastewater service shall be of the Swing Flex full body flange type with domed access cover and only one moving part, the valve disc.

The valve body shall have full flow equal to nominal pipe diameter at any point through the valve. The seating surface shall be on a 45 degree angle to minimize disc travel. The top access port shall be full size allowing removal of the disc without removing the valve from the pipeline.

Valve body and cover shall be ASTM A126, Class B cast iron. The disc shall be Buna-N (NBR) ASTM D2000-BG. The exterior shall be coated with a universal primer.

Backflow capabilities shall be furnished by means of a screw type backflow actuator. The actuator shall be field installable without modification to the valve, a need for special tools, or removal of the valve from line.

The disc shall be of one-piece construction, precision-molded with an integral o-ring sealing surface and contain steel and nylon reinforcements in both the flexible and central disc areas. The flexible portion of the disc shall be warranted for 25 years. Non-slam closing characteristics shall be provided through a short 35 disc stroke and memory flex disc return action.

The valve shall be cycle tested 1,000,000 times with no signs of wear or distribution to the valve disc or seat and shall remain drop-tight at both high and low pressures. The test results shall be independently certified.

Rubber flapper check valves shall be suitable for sewage and sludge service and be manufactured by Val-Matic, Series 500, APCO, or equal.

7.10 Accessories

A. Slide Rail System

A slide rail system shall be provided for easy removal of the pumps for inspection and service. The system shall not require a man to enter the wet well to remove the pump and motor assembly.



DESIGN AND CONSTRUCTION STANDARDS

Two (2) guide rails of 2-inch stainless steel pipe shall be provided for each pump. The guide rails shall be positioned and supported by the pump mounting base. The guide rails shall be aligned vertically and supported at the top by attachment to the access hatch frame with a stainless-steel upper guide rail mounting bracket.

One (1) intermediate stainless steel guide rail support is required for every 10-feet of guide rail length for stainless steel pipe.

The pumps are equipped with sliding brackets or rail guides. To ensure easy removal of the pumps, the rail guides attached to each pump shall not encircle the rails.

A stainless steel lifting cable of adequate length for the basin depth shall be provided for each pump.

The rails and the rail guides shall function to allow the complete weight of the pumping unit to be lifted on dead center without binding and stressing the pump housing. The rail system shall function to automatically align the pumping unit to the discharge connection by a simple downward movement of the pump. No twisting or angle approach will be considered acceptable.

B. Access Hatches

Frames shall be ¼-inch extruded aluminum with built-in neoprene cushion and with strap anchors bolted to the exterior. Cover leaf shall be ¼-inch aluminum reinforced with aluminum stiffeners as required. Stainless steel hinges shall be bolted to the underside and pivot. All stainless-steel bolts and hardware shall be used. The cover shall open to 90-degrees and lock automatically in that position. A vinyl grip handle shall be provided to release and close the cover with one hand. Covers shall be built to withstand a live load of 300 pounds per square foot and equipped with a snap lock and removable handle. When closed, the covers shall not protrude above the operating surface in which they are installed. Factory finish shall be aluminum lacquer. Surface contacting concrete shall have bituminous coating. Covers shall be diamond pattern plate. Aluminum covers shall be Bilco, Halliday, or equal.

When flush mounted covers are furnished, two (2) wrenches shall be provided for opening the covers. The valve vault cover shall be watertight with a drain system. A safety grate shall be furnished and installed with each hatch.



C. Portable Hoist

Furnish and install for each pump station (1) portable hoist along with a winch, cable, and hook capable of lifting one pump. The hoist and associated lifting equipment shall have a minimum capacity of 150% of the weight of one pump. One (1) hoist shall be provided to be used for all pumps provided.

A surface-mounted socket shall be provided and anchored into the top of the concrete slab over the wet well for each pump as shown on the Plans. Any additionally reinforcing and appurtenances required to install the socket assembly shall be provided by the manufacturer or Contractor.

The hoist shall be provided with a pump lift gripper as a means to easily connect the hook, hoist the pump, and disconnect the hook without needless intermediate reconnecting.

D. Cable Holder

A stainless-steel cable and chain holder shall be mounted inside the hatch opening of the top slab of the wet well to support the pump power and control cables and lifting cable.

7.11 Control Panel

The control panel shall be built in a NEMA 4X stainless steel enclosure and shall be suitable for the specified horsepower and voltage for the pumping equipment. The outer door of the panels shall be hinged dead front with provisions for locking with a padlock. All buttons, lights, switches, meters, etc. shall be installed on an interior hinged door.

The NEMA 4X enclosure shall be sized to accommodate all control components and have an additional 10% spare space for future use. The outer door of the enclosure shall be able to accommodate a padlock. The enclosure shall be fabricated of Type 304 Stainless Steel with a white-painted steel removable sub-panel. There shall also be an aluminum inner swing-out panel for mounting the Operator devices. Circuit breaker handles shall also protrude through the inner door for ease of access.

A main circuit breaker and emergency power circuit breaker shall be provided with a walking beam interlock to prevent turning both on simultaneously. Operator handles shall be mounted through the inner door. The circuit breaker shall be Type FAL as manufactured by Square D.



DESIGN AND CONSTRUCTION STANDARDS

A generator receptacle shall be mounted to the side of the enclosure. It shall be of the pin and sleeve type with reversed pins. The receptacle shall match the Town's existing portable generator. Verification must be done by the Contractor prior to submittals being sent.

Each pump shall have a three-pole circuit breaker. The breakers shall be manufactured by the same manufacturer as the NEMA-rated starters and protrude through the interior panel. All motors shall have an individual thermal magnetic circuit breaker. Circuit breakers shall be sized at not less than 200% of motor full load amperes (FLA) and not more than 250% of motor FLA.

Each pump shall have a NEMA-rated motor starter. The starters shall be as manufactured by Square D, Type 8536. Each motor starter shall include a solid-state overload relay sized according to the motor's FLA and the Square D sizing charts. Overload reset push buttons shall be mounted on the inner door for each starter. Each pump shall have a hand-off-auto selector switch mounted on the inner door with green run lights. NEMA size 2 shall be the smallest acceptable size.

The "H-O-A" selector switch shall be provided for each pump. In "Hand" the pump shall run. In "Auto" it shall be controlled by the pump level controller.

The pump level controller shall alternate the pumps on each successive cycle of operation.

Provide control power transformers for 120VAC and 24VAC control wiring. Transformers shall be sized to meet the requirements of the control circuit involved. Include a separate switch and fused/circuit breaker protection for each transformer.

All switches and lights shall be corrosion resistant and be of the 22 MM Type, similar to Sprecher & Schuhl.

A seal failure relay shall be installed to monitor the seals in the pumps. It shall be as required by the pump manufacturer. Upon failure, the relay shall energize an alarm indicator light (amber) and not shut the pump off.

The pump shall also have over-temp protection in the windings of the motor. These shall be wired to shut the pump off and be automatic reset. An indicating light (amber) shall be activated and be maintained until the alarm is acknowledged with a reset button.

Include an interior panel heater to maintain electronic device functionality.



DESIGN AND CONSTRUCTION STANDARDS

All motors shall be protected by an adjustable, automatic resetting phase failure relay. The relay shall be installed inside the pump control panel motor starter enclosure.

The control center shall include an hour meter for each pump to register the elapsed operating time of each pump.

The entire pump control panel shall be protected by a Transient Voltage Surge Suppressor (TVSS) with a minimum 300 KAIC surge current capability, similar to Liebert AccuVar series.

The control center shall have a high-water alarm built-in the main enclosure. The high-water alarm shall consist of a flashing alarm light with red Lexan plastic cover or red glass globe with metal guard mounted on top of the enclosure such that is visible from all directions and an audible horn. A push to test light button shall be provided and mounted inside the enclosure. A push to silence button shall be mounted on the exterior of the panel.

A reset push button shall be provided to reset the following alarm conditions: Low level, high level, and motor high temperature. Only the high-level alarm shall activate the local horn and strobe.

Pump controller shall be standard "off the shelf" equipment with published literature and fully tested hardware and operating program. The device must be field configurable from the front of the unit and require no special tools or software to set-up and operate. It shall be a microprocessor-based device and not require a battery to maintain the operating program. All set-up values shall be stored in non-volatile memory. The pump control unit shall use a submersible pressure transducer to indicate the wet well level and alternate the pumps on each successive cycle of operation. The pump control device shall be as manufactured by MPE, Inc. Model SC2000.

Provide Omni-Site.net alarm dialer (XR-50 Micro RTU), coax cable, battery backup, and cell phone antenna. Provide alarm, status, and control wiring interface to the alarm dialer as indicated on the plans. Program dialer and place into service, except the Owner shall be responsible for cell phone and website service contract. Provide terminal block for field wiring of input/output (I/O) connections. Provide all I/O points and functions indicated. Wire I/O wiring to the terminal block.

All components of each control center shall be American made and available from local sources. In particular, items such as circuit breakers, overload protection, relays, etc., shall be available and in stock by local resources.



DESIGN AND CONSTRUCTION STANDARDS

All items in the control panel shall be labeled and identified with Brady style labels. The component identification shall match the schematic diagram that accompanies the control panel. All items on the interior door and exterior to the panel shall be labeled with engraved plastic laminate tags

In order to maintain unit responsibility and warranty on the pumping equipment and control center, each control center must be accepted in writing by the pump manufacturer and suitable for operation with the pumping equipment.

There shall be a termination strip with box type connectors to make all power and control connections for the pumps, floats, and transducer. All terminals shall be marked for easy identification. A ground terminal strip shall be provided also.

All wiring shall be minimum 600-volt UL Type MTW or AWM and have a current carrying capacity of not less than 125% of the full load current. The conductors shall be in complete conformity with the National Electric Code, State, Local and NEMA Electrical Standards. For ease of servicing and maintenance, all wiring shall be color coded or numbered on each end. The wire color or number shall be clearly indicated on all submittal and as-built drawings.

Provide NEMA 4X enclosed FUSIBLE, heavy duty disconnect switch, UL Service Entrance rated with grounding kit for use as the main service entrance switch. Provide Bussman fuses as applicable for the service entrance size.

Provide a utility acceptable meter base. Coordinate with local electrical utility's requirements.

The lift station control panel, disconnect switch, and meter base shall be attached to an aluminum welded support frame.

The Control Panel shall be assembled and provided by a Town-approved local supplier.

7.12 Level/Pump Control System

Five (5) sealed float-type mercury switches shall be supplied for each lift station control sump level and alarm signal. The mercury tube switches shall be sealed in a solid polyurethane float for corrosion and shock resistance. The support wire shall have a heavy Neoprene jacket and a weight shall be attached to the cord above the float to hold the float in place in the sump. The floats shall also be capable of supporting themselves from a wiring channel support bar or capable of being attached to a plastic chain with a weight at the bottom of the chain. The float switches shall be the backup system if the submersible pressure transducer or pump controller should fail.



Primary level controls shall be from a submersible transducer. The transducer shall consist of a bonded foil, strain gauge, sensing element, encased in an explosion-proof designed 316 stainless steel housing. A large diameter stainless steel diaphragm seal shall be non-clogging and resist damage from floating solids. Cable shall be of 220-pound tensile strength, shielded, vented, Tefzel cable. The unit shall be calibrated for 0 to 15 psi and include forty feet of cable. The transducer shall weight at least 14-pounds, not including the cable. The transducer shall be installed within a 6-inch PVC stilling tube mounted to the side of the wet well. Transducer shall be manufactured by KPSI Series 750 with optional lightning protection, or equal.

7.13 Operation of System

There are five (5) levels within the wet well for normal operation of the system. The first level is for low level alarm and shut off. The next two levels are for starting and stopping the pumps. When the level reaches the pump "on" level, the "lead" pump shall start and continue to run until the "off" level is reached. The two pumps shall alternate on each on/off cycle. The fourth level is to turn on the "lag" pump should the lead pump fail to start or cannot keep up with the influent flow. The fifth level is to alert the Operator that the wet well is at a high-water level and shall activate the alarm system.

The level controller shall also have a five-float redundant backup, which shall operate the pumps in the event of a transducer or controller failure. The backup system shall be totally automatic. The floats shall be placed above normal control range of the controller and submersible level transmitter.

7.14 Electrical Components

Provide engraved nameplates for all major devices and equipment. Include detailed instructions on the connection and transferring over to a portable generator. Identify and label all conductors with Brady style labels.

Provide schedule 40 PVC for utility service lateral and riser only. Include a galvanized rigid steel (GRS) elbow and stub where the conduit turns up at the meter base location. Install the conduit a minimum of 36-inch below grade with detectable warning tape 12-inch below grade.

Provide galvanized rigid steel conduit for all above grade and below grade conduit unless noted otherwise. Include hot dipped galvanized conduit fittings and hubs as required.



DESIGN AND CONSTRUCTION STANDARDS

All conduit from the wet well to each control panel shall have conduit seals to prevent gases from the wet well from entering the control panels. The classification of the wet well is Class 1, Division 1, Group D; provide appropriately rated fittings for this installation

Include link type seals where conduits enter the wet well. Link Seal model #S-316 or equal.

Power conductors shall be type THWN-THHN: For dry and wet locations, the maximum dry location operating temperature is 90 Deg. C. Insulation shall be flame-retardant, moisture-resistant, and heat-resistant thermoplastic; outer covering shall be nylon jacket. All conductors shall be copper.

All terminals shall be rated for copper conductors. Dual rated lugs shall be acceptable.

Provide a solidly grounded service ground electrode system. Include an equipment grounding conductor for all circuits.

Provide stainless steel Kellems-type grips to support all cables from the cable holder in the wet well.

7.15 Station Warranty

The overall station warranty shall be one (1) year from the date of acceptance per Town maintenance bond requirements. Included under the warranty shall be all concrete structures, pumps valves, piping, controls, electrical equipments, and all other appurtenances listed within the Standards and necessary for the operation of the lift station. The pumps shall be provided with a 5-year prorated warranty.

SECTION 8
INSTALLATION AND CONSTRUCTION
OF SANITARY SEWERS

<u>Section</u>	<u>Description</u>	<u>Page</u>
8.01	General.....	8-1
8.02	Excavation	8-1
	A. Dewatering and Control of Surface Water	8-1
	B. Site Preparation	8-1
	C. Excavating.....	8-2
	D. Trenching	8-3
8.03	Bedding and Backfill	8-4
	A. General	8-4
	B. Bedding and Backfill Materials.....	8-4
	C. Backfill of Trench Excavations for Pipes and Conduits.....	8-6
	D. Bedding.....	8-6
	E. Backfill Around Pipe	8-7
8.04	Installation of Sewers	8-8
	A. General	8-8
	B. Installation of Sewers	8-8
8.05	Installation of Force Mains.....	8-9
	A. General	8-9
	B. Installation of Force Mains	8-9
8.06	Structure Installation	8-10

8.07 Installation of Building Sewers (Laterals)8-11

- A. General8-11
- B. Connection to Sanitary Sewers8-11
- C. Connection to Sanitary Manholes8-12
- D. Bedding and Backfill8-12
- E. Laying of PVC Building Sewer8-12



SECTION 8

INSTALLATION AND CONSTRUCTION OF SANITARY SEWERS

8.01 General

This section shall provide general, minimum requirements for the installation and construction for Town of Hebron sanitary sewer projects.

8.02 Excavation

A. Dewatering and Control of Surface Water

Where groundwater is encountered, the Contractor shall make every effort necessary to secure a dry trench bottom before laying pipe. The Contractor shall provide, install, and operate sufficient trenches, sumps, pumps, hoses, piping, well points, etc., necessary to depress and maintain the groundwater level below the base of the excavation. If the Contractor is unable to remove the standing water in the trench, the Contractor shall over-excavate the proposed bottom grade of the sewer bedding, and place not less than 3-inches of Class No. 3 crushed stone (per INDOT aggregate classification) in the over-excavated area.

The Contractor shall keep the site free of surface water at all times and shall install drainage ditches, dikes, pumps, and perform other work necessary to divert or remove rainfall and other accumulation of surface water from excavations. The diversion and removal of surface and/or groundwater shall be performed in a manner which will prevent the accumulation of water within the construction area.

Under no circumstances shall surface water and/or groundwater be discharge to, disposed of, or allowed to flow into the Town's Sanitary Sewer System.

B. Site Preparation

Before any excavation is started, adequate protection shall be provided for all lawns, trees, landscape work, shrubs, fences, hydrants, sidewalks, and other objects that are to remain in place. Such protection shall be



DESIGN AND CONSTRUCTION STANDARDS

maintained for as long as necessary to prevent damage from the Contractor operation.

Moveable items such as mailboxes and roadway signs may be temporarily relocated during construction. Place moveable items in their original location immediately after backfilling is complete. Moveable items damaged during construction shall be replaced with new items at the Contractor's expense.

Strip topsoil and vegetation from the excavated areas. Clean topsoil may be stockpiled for re-use as the upper 6-inches of the area to be seeded. Do not intermix grass, weeds, roots, brush, and stones larger than 1-inch with stockpiled topsoil. Dispose of root contaminated topsoil.

Clear and remove logs, stumps, brush, vegetation, rubbish and other perishable matter from the job site. Do not remove or damage trees that do not interfere with the work. Completely remove trees including stumps and roots that are required to be removed. Replace trees removed unnecessarily and properly treat damaged trees that can be saved.

Remove existing pavement and walks from the excavated areas. Remove asphaltic and concrete materials from the job site as these materials are excavated. Use methods to remove pavement and walks that will assure the breaking or cutting along straight and vertical lines. Remove walks completely where excavation is along the length of a walk. Remove walks to existing joints where excavation crosses walks. The width of pavement to be removed shall not exceed the width of the trench by more than 12-inches on each side of the trench.

C. Excavating

Excavated materials suitable and necessary for backfilling shall be stored in a neat pile adjacent to the excavation in a manner so as to interfere as little as possible with traffic. Such materials shall not be placed with sufficient height or proximity to excavation so as to endanger such openings due to earth slides or cave-ins.

Excavated material not suitable for backfilling and excess suitable material shall be removed from the job site and disposed of in a spoil area secured by the Contractor and approved by the Town.

Provide and maintain adequate dewatering equipment to remove and dispose of surface and ground water entering excavations. Use diversion



ditches, dikes, or other suitable means to prevent surface water from entering the excavation and to provide adequate drainage of the area adjacent to the excavation.

D. Trenching

Excavate trenches to a depth and width as required by the pipe manufacturer for proper installation of the pipe and appurtenances. Excavations below the required grade shall be filled with compacted bedding material.

The trench width for concrete box sections shall be only as wide as is necessary to facilitate proper compaction of backfill material, provided the adjacent embankment material is structurally adequate to provide the necessary side support. Verification of sufficient bearing strength of underlying soil foundation material, based upon manufacturer's recommendations, shall be required for all reinforced concrete box section installations.

Trenches shall be made as narrow as possible and to the straight lines shown on Plans. Sides of trenches shall be kept as near vertical as possible and shall be properly sheeted and/or braced, if required. The width of the trench shall provide a clearance of not less than 8-inches no more than 10-inches on each side of the pipe.

Provide a continuous, uniform bearing support for the pipe on solid undisturbed soil or compact granular fill with trench dished to provide circumferential support to the lower third of each pipe. Dig out holes to receive pipe bells.

Rock excavation encountered in the trench and soft material which, in the opinion of the Town is incapable of providing adequate bearing to support the pipe, shall be removed to a depth of 4-inches below the required elevation and filled with compacted granular fill material.

Do not open more than 50-feet of trench in advance of the installed pipe, unless otherwise directed or permitted by the Town. Excavate the trench within 6-inches of full depth for a distance of at least 30-feet in advance of the pipe installation, unless otherwise directed or permitted.

Maintain one lane of traffic at all streets and service drives during construction. Streets and drives may be closed, and traffic detoured if



DESIGN AND CONSTRUCTION STANDARDS

permission is obtained by the Contractor from the State, City, County, or Local Business having jurisdiction.

Any sewer, gas, water, or other pipes or conduits crossing the trench shall be supported without damage and without interrupting service. The manner of supporting such pipes or conduits shall be subject to the approval of the Town and/or the inspector of the utility involved.

The Contractor shall provide adequate sheeting and bracing in open cut trenches to protect life, property, and the work.

All sheeting, planking, timbering, shoring, bracing, and bridging shall be placed, renewed and maintained, and shall not be removed until sufficient backfill has been placed to protect the pipe.

Where rock is encountered during trenching operations, the Contractor may remove the rock by mechanical means. The use of a rock trencher which produces excavated material commensurate to “granular backfill” is preferred. Materials suitable for granular backfill excavated by a rock trencher may be used as bedding for pipe in areas of rock excavation. If the Contractor removes the rock by the use of controlled explosives, he shall employ a licensed blasting supervisor and crews experienced in explosive demolition and excavation. Prior to any blasting operations, the Owner/Contractor shall submit to the Town the blasting supervisor’s experience record, a monitoring and control program showing the blasting area, charge per round in pounds, and storage procedures for explosives.

No farm fences shall be cut when gates are available within a reasonable distance to move equipment from one field to another.

8.03 Bedding and Backfill

A. General

All trenches or excavations shall be backfilled to the original surface of the ground or such other grades as required or directed. In general, the backfilling shall be carried along as speedily as possible in order to avoid open excavations.

B. Bedding and Backfill Materials

Bedding and Backfill material classes referenced within this section shall be defined as follows:



DESIGN AND CONSTRUCTION STANDARDS

- Class I** Angular, 6- to 40-millimeters ($\frac{1}{4}$ - to $1\frac{1}{2}$ -inch) graded stone such as crushed stone. A No. 8 gravel possessing a minimum 50% mechanical crush count, and meeting the following nominal sizes and percents passing will be considered an equivalent Class I material (100% passing 1-inch sieve; 75-95% passing a $\frac{3}{4}$ -inch sieve; 40-70% passing $\frac{1}{2}$ -inch sieve; and 0-15% passing No. 4 sieve).
- Class II** Coarse sands and gravel-sand mixtures with a maximum particle size of 40-millimeters ($1\frac{1}{2}$ -inches), including variously graded sands and gravels containing small percentages of fine, generally granular and non-cohesive, either wet or dry. Soil types GW, GP, SW and SP are included in this class (INDOT Classification for Structural Backfill).
- Class III** This class is defined as fine sand and clay gravels, including fine sands, sand-clay mixtures and gravel-clay mixtures. Soil types GM, GC, SM and SC (ASTM D2487) are included in this class. These materials will not be accepted as pipe bedding.
- Class IV** Silt, silty clays and clays, including organic-clays and silts of medium to high plasticity and liquid limits. Soil types MH, ML, CH and CL (ASTM D2487) are included in this class. These materials will not be accepted as pipe bedding.
- Flowable Fill** Unconfined Compressive Strength (28 day) 50 - 150 psi
Flow Test - Diameter of Spread > 8 inches \pm 1-inch
- 1) Design - Mix design must be submitted to and approved by the Town. A trial batch demonstration may be required. The mix design shall include a list of all ingredients, the source of all materials, the gradation of all aggregates, the names of all admixtures and dosage rates, and the batch weights. Except for adjustments to compensate for routine moisture fluctuations, minor mix design changes after the trial batch verification shall be documented and justified prior to implementation by the Contractor. A change in the source of materials or addition or deletion of admixtures or cementitious materials will require the mix design to be resubmitted for approval. The Contractor may be required to provide test data from a laboratory inspected by the Cement and Concrete Reference Laboratory, and approved by Town, which shows that the proposed mix design is in accordance with the requirements listed in this specification.



DESIGN AND CONSTRUCTION STANDARDS

2) Flow Test - The test for flow shall consist of filling a 3-inch diameter by 6-inch-high open ended cylinder placed upon a smooth, nonporous, level surface to the top with flowable fill. The cylinder shall be pulled straight up within 5 seconds. The spread of the fill shall be measured. The minimum diameter of the spread shall be 8-inches. There shall be no noticeable segregation and the material spread shall be at least 8-inch diameter

3) Placement - The mixture shall be discharged from mixing equipment by a reasonable means into the space to be filled. The flowable fill shall be brought up uniformly to the fill line. Each filling stage shall be as continuous as is practicable. Concrete may be placed on the flowable fill as soon as bleeding water has subsided. All pavements shall be placed according to flowable fill manufacturer's recommendations.

4) Limitations - Flowable fill shall be protected from freezing until the material has stiffened and bleeding water has subsided. As the temperature nears freezing, additional curing time may be needed.

C. Backfill of Trench Excavations for Pipes and Conduits

Bedding and Backfill materials samples shall be submitted to the Town prior to start of construction.

D. Bedding

1. Plastic (PVC, HDPE) Pipe

Plastic pipe conduits (PVC and HDPE) shall be provided with No. 8 crushed stone or approved Class I granular bedding material shovel sliced or otherwise carefully placed and "walked" or hand tamped into place from 4- to 8-inches (based in the diameter of the pipe) below the pipe barrel, to a minimum of 12-inches above the crown of the pipe.

Bedding and initial backfill material shall be hand placed around the haunch and sides of the plastic pipe, to ensure proper compaction filling of all voids.

Bedding shall be placed in 6-inch to 8-inch balanced lifts.



2. Ductile Iron Pipe (DI)

Ductile Iron Pipe (DI) conduits shall be provided with Class I or Class II granular bedding material. Class I material shall be shovel sliced or otherwise carefully placed and “walked” or hand tamped into place from 3- to 6-inches (based upon pipe diameter) below the pipe barrel, to 1/6th the outside pipe diameter (Bc). Class II material shall be compacted to 90% Standard Proctor Density as a minimum, except where the edge of the pipe trench is located within the pavement zone as specified herein, where Class II material shall be compacted to 95% Standard Proctor Density.

E. Backfill Around Pipe

Do not backfill trenches until all piping and utilities have been inspected and until the piping system, as installed, conforms to the requirements as detailed in these Standards and are approved by the Town.

Backfill all trenches within State Highway Right-of-Way in accordance with Indiana Department of Transportation Specifications. Backfill trenches in rights-of-way in accordance with the requirements of public authority having jurisdiction.

Initial backfill material shall be hand placed around the haunch and sides of the Plastic Pipe (PVC or HDPE) to ensure proper compaction filling of all voids. Initial backfill shall be placed in 6-inch to 8-inch balanced lifts.

Backfill trenches for mainline sewers under existing paved roads, curbs, and gutters with flowable fill. Backfill trenches for mainline sewers under future roads, curbs, and gutters with compacted granular backfill. Prepare upper portion of the trench accordingly for surface restoration or pavement replacement.

Compacted granular fill shall be used for backfilling trenches in the following areas: (1) for sewer laterals under paved roads, curbs, and gutters to 5-feet from the edge of pavement or backside of curb; (2) for mainline sewers and laterals under paved drives, paved alleys, and sidewalks within 5-feet from the edge of pavement or backside of curb; and (3) for mainline sewers and laterals not under paved roads but within 5-feet of the edge of pavement. Place backfill in 8-inch layers and compact to 95% Standard Proctor Density. Prepare upper portion of the trench for surface restoration or pavement replacement.



Backfill trenches at unpaved driveways and alleys with suitable excavated material up to the last 12-inches which shall be the same material as the original surface. Place backfill in 8-inch layers and compact to 95% Standard Proctor Density.

Backfill trenches under sidewalks greater than 5-feet from roadways with suitable excavated material placed in 8-inch layers and compacted to 95% Standard Proctor Density.

Backfill trenches in areas not requiring flowable or granular fill with suitable excavated material compacted to produce an adequate foundation for seeding. The top 4-inches of backfill shall not contain stones or other objects larger than 1-inch in maximum dimension. Mound backfill above the finished grade to allow for settlement. Place 6-inches of clean topsoil over the area to be seeded. Grade area to be restored settlement and immediately before restoration.

Maintain backfilled trenches in a smooth and uniform condition until paving or seeding operations are completed. Contractor shall refill and restore to the original grade any settlement in the backfill which takes place within the 1-year warranty period at no additional cost to the Town.

For all areas requiring compacted granular backfill to meet 95% Standard Proctor Density, perform compaction tests in accordance with the standard specifications of the Indiana Department of Transportation. The Contractor shall be responsible for payment of all compaction tests.

8.04 Installation of Sewers

A. General

The Contractor shall provide all tools, labor and equipment necessary for the safe and expeditious installation of all sanitary sewers, manholes, and appurtenances.

Inspect sewer pipe, manhole sections, and appurtenances prior to installation and promptly remove damaged or unsuitable materials with new and unused materials.

B. Installation of Sewers



DESIGN AND CONSTRUCTION STANDARDS

Sewer pipe shall be laid uniformly to line and grade so that the finished sewer will present a uniform bore.

The Contractor, at his own expense, shall set line and grade by means of laser beam and target for alignment and grade.

Sewer pipe shall be laid progressively upgrade with bell upstream in a manner to form close, concentric joints with smooth bottom inverts.

After the joint is made, sufficient bedding material shall be placed along each side of the pipe to prevent conditions that might tend to move the pipe off line or grade.

Installed piping systems shall be temporarily plugged at the end of each day's work, or other interruption of progress on a given line. Plugging shall be installed in a manner satisfactory to the Town and it shall be adequate to prevent entry of animals into the pipe or insertion of deleterious materials.

A mechanical plug shall be installed at the end of all sewer stubs for future sewer extensions.

8.05 Installation of Force Mains

A. General

The Contractor shall provide all tools, labor and equipment necessary for the safe and expeditious installation of all force mains and appurtenances.

Inspect force main pipe and appurtenances prior to installation and promptly remove damaged or unsuitable materials with new and unused materials.

B. Installation of Force Mains

Force mains shall be laid uniformly to line and grade so that the finished sewer will present a uniform bore. The Contractor, at his own expense, shall set force main alignment and grade for all sewers.

HDPE force mains shall be butt fusion bonded at grade level and lowered into the trench using nylon slings to avoid damage to the pipe. Chains or cable type chokers must be avoided when lifting used sections of pipe.



DESIGN AND CONSTRUCTION STANDARDS

Sewer pipe shall be laid progressively upgrade with bell upstream in a manner to form close, concentric joints with smooth bottom inverts.

After the joint is made, sufficient bedding material shall be placed along each side of the pipe to prevent conditions that might tend to move the pipe offline or grade.

Installed piping systems shall be temporarily plugged at the end of each day's work or other interruption of progress on a given line. Plugging shall be installed in a manner satisfactory to the Town and it shall be adequate to prevent entry of animals into the pipe or insertion of deleterious materials.

After the main is installed, sufficient bedding material shall be placed along each side of the pipe to prevent conditions that might tend to move the pipe offline or grade. Bedding of #8 crushed stone shall be provided from 4-inches below the pipe to 12-inches above the crown of the pipe.

Locate tape and wire shall be installed above all force mains within 2-feet of the finished grade. Tracer wire shall be installed above PVC force mains. It is the responsibility of the Contractor to protect these markers and to verify that all force mains have been properly marked.

8.06 Structure Installation

Manhole excavation shall be kept free from water during construction. Space excavated below the depth required for the manhole base shall be refilled with compacted sand or crushed stone at the Contractor's expense.

Manhole floors shall be formed with concrete to a depth of $\frac{1}{2}$ the incoming sewer size with the floor sloped to the sewer invert. Floors for "straight through" manholes shall be formed by laying the pipe straight through the manhole, pouring the concrete and then cutting out the top half of the pipe. Floors shall be constructed as the manhole is being built and this thickness is in addition to the 8-inch base required.

Precast concrete risers and adjusting rings shall be used in such combination that the top of the eccentric cone section, when installed, will be at a proper elevation for the manhole frame. Concrete adjusting rings shall be allowed up to a maximum of 12-inches height adjustment. Manholes needing more than 12-inches adjustment shall have a concrete riser section installed to the proper elevation.



DESIGN AND CONSTRUCTION STANDARDS

Manhole frames shall be brought to grade, centered and embedded in a mastic bonding course. Manhole frames shall be bolted or anchored through adjusting rings and into the cone section of the manhole using stainless steel all-thread or expansion bolts.

Steps shall be built into all manholes 4-feet in depth or greater and shall begin 8-inches below the bottom of the chimney. Steps shall be installed at 16-inches on center maximum.

Precast concrete risers and cone sections shall be installed so that the axis of the manhole is vertical. Gaskets for the riser joints shall be installed in accordance with the manufacturer's recommendations. Riser joints shall be wrapped with external joint seals in accordance with manufacturer's recommendations.

Unless otherwise indicated, castings for manholes shall be set at finish grade level. This Contractor shall be responsible for adjusting the casting to the satisfaction of the Town at the Contractor's expense.

The Contractor shall remove all debris and excess soil from the manholes after construction and prior to flushing the sewer pipes to the satisfaction of the Town.

8.07 Installation of Building Sewers (Laterals)

A. General

Laterals shall be installed at a normal slope of $\frac{1}{4}$ -inch per foot. Minimum slope shall be $\frac{1}{8}$ -inch per foot. A mechanical plug shall be installed at the end of each lateral. It shall be the responsibility of the Contractor to install the lateral at a depth sufficient to allow each customer to connect to the end of the lateral.

A piece of resteel shall be installed at the end of each sewer lateral for marking. It shall be the responsibility of the Contractor to protect these markers and to verify that all laterals have been properly marked.

B. Connection to Sanitary Sewers

Connections to new sanitary sewers shall be made only at the manufactured fitting. Connections to existing sanitary sewers shall be made at existing manufactured fittings, as shown on the approved record drawings. In the event that no manufactured fitting exists in an existing sanitary sewer, and if approved by the Town, a service connection may be



DESIGN AND CONSTRUCTION STANDARDS

made using a saddle connection or by cutting into the sewer and installing a manufactured fitting using Fernco couplings.

C. Connections to Sanitary Manholes

Connections to sanitary manholes shall not be made without prior approval of the Town. Building sewers shall connect to the manhole, when approved, at the manhole invert. Under these circumstances, the manhole base shall be pre-formed with a gasketed connection for the lateral line. The invert shall also be formed at the flow line to accept the lateral sewer connection. No inside drop connections shall be allowed without the prior written approval of the Town.

D. Bedding and Backfill

Bedding and Backfill shall be required per the specifications for PVC flexible pipe included in these Standards.

E. Laying of PVC Building Sewer

The point of commencement for laying of the building sewer pipe shall be at the connection to the sanitary sewer and shall be laid with the bell end pointing upgrade.

Whenever a service lateral must go under street pavement to get to the building to be served, an additional 6-inch cleanout shall be installed at the edge of the right-of-way, on the building private property.

Tracer wire and location tape shall be installed from the connection to the mainline sewer to the edge of the right-of-way or easement.

SECTION 9

EROSION CONTROL

<u>Section</u>	<u>Description</u>	<u>Page</u>
9.01	General.....	9-1
	A. Description	9-1
	B. Submittals	9-2
9.02	Materials	9-2
	A. Grass.....	9-2
	B. Mulches.....	9-2
	C. Fertilizer	9-2
	D. Straw Bale Dike.....	9-2
	E. Slope Drains and Erosion Control Blanket/Matting	9-3
	F. Silt Fencing	9-3
	G. Construction Entrance / Gravel Drive Tracking.....	9-3
	H. Inlet Protection Bag.....	9-3
	I. Curb Inlet Protection	9-3
	J. Rip Rap Check Dams.....	9-3
	K. Concrete Washout Area.....	9-3
	L. Other	9-4
9.03	Execution.....	9-4
	A. General	9-4
	B. Schedule	9-4
	C. Authority of Town	9-4
	D. Dust Control	9-4
	E. Sediment Tracking	9-5
	F. Construction Details.....	9-5
	G. Inspections	9-6
	H. Inspection Reports	9-7
	I. Maintenance.....	9-7



SECTION 9

EROSION CONTROL

9.01 General

A. Description

The Contractor shall be responsible for all temporary and permanent control measures to control water pollution, soil erosion, and siltation through the use of berms, dikes, dams, sediment basins, fiber mats, gravel, mulches, grasses, slope drains, and other erosion control devices or methods.

The Contractor shall comply with all requirements of IDEM's Construction Storm Water General Permit (CSGP), formerly known as Rule 5, Storm Water Runn-Off Associated with Construction Activities. The Contractor shall be responsible for notifying all agencies and posting all public notices necessary to comply with the CSGP and the local Soil and Water Conservation District (SWCD) and/or Municipal Separate Storm Sewer System (MS4) regulations. The following information shall be posted at the project site: Notice of Intent (NOI) letter and NPDES permit number; the name, address, and phone number of the local contact person; and the location of a copy of the construction plans.

Temporary erosion control measures shall be coordinated with the permanent erosion control measures to the extent practical to assure economical, effective, and continuous erosion control throughout the construction period.

Temporary control may include work outside the construction limits such as borrow pit operations, equipment, and material storage sites, waste areas, and temporary plant sites.

Material handling and storage associated with construction activity shall meet the spill prevention and spill response requirements in Indiana Administrative Code 327 IAC 2-6.1.



B. Submittals

The Owner shall provide verbal or written notification to the local regulator (SWCD or MS4), IDEM, and the Town within 48-hours or the start of construction to give the actual start date.

The Owner shall be notified when land disturbing activities have been completed, the entire site has been stabilized, and all temporary erosion control measures have been removed. The Owner shall submit a Notice of Termination (NOT) letter to IDEM, the local SWCD or MS4, and the Town.

9.02 Materials

A. Grass

Grass which will not compete with the grasses sown later for permanent cover shall be a quick-growing species (such as ryegrass, Italian ryegrass, or cereal grasses) suitable to the area providing a temporary cover.

B. Mulches

Mulches may be hay, straw, fiber mats, netting, bark, wood chips, or other suitable material reasonable clean and free of noxious weeds and deleterious materials.

C. Fertilizer

Fertilizer shall be a standard 12-12-12 commercial grade and shall conform to all federal and state regulations and to the standards of the Association of Official Agricultural Chemists.

D. Straw Bale Dike

Straw bale filters shall be used for the slowing and filtering of storm water before it enters storm water conveyances such as driveway culverts or other inlet structures that drain small drainage areas. Do not use across a stream, ditch, channel, swale, or where concentrated flows will occur.



E. Slope Drains and Erosion Control Blanket/Matting

Where construction disturbs grassy slopes equal or steeper than 3:1, the slope shall be protected with an erosion control mat. Slope drains may be constructed of pipe, fiber mats, rubber, Portland cement concrete, bituminous concrete, or other materials that will adequately control erosion.

F. Silt Fencing

Silt fencing shall be used to prevent soil erosion at the top of slopes.

G. Construction Entrance / Gravel Drive Tracking

A construction entrance shall be used to prevent tracking of mud or soil onto publicly or privately owned paved surfaces. Not all locations of construction entrances may be shown on the Plans. The Contractor is responsible for locating and placing construction entrances to prevent tracking and to avoid disturbances to existing waterways.

H. Inlet Protection Bag

Inlet protection bags shall be installed in all storm water inlets within the construction area or impacted by construction area storm water run-off to prevent sediments, construction debris, and other potential storm water pollutants from entering storm sewer inlets and catch basins.

I. Curb Inlet Protection

Curb inlets receiving run-off from construction areas shall be protected to prevent sediments, construction debris, and other potential storm water pollutants from entering storm sewers.

J. Rip Rap Check Dams

Rip rap check dams shall be installed to reduce erosion potential and capture potential pollutants.

K. Concrete Washout Area

The Contractor shall provide a designated concrete washout area for use of washing out concrete trucks and depositing excess concrete to contain



DESIGN AND CONSTRUCTION STANDARDS

potential storm water pollutants. The area shall be roughly 10'x10x'3' deep (minimum). The area shall have the contents removed periodically. The areas shall be reused throughout the construction phase. Other methods may be used upon approval by the Town.

L. Other

All other materials shall meet commercial grade standards and shall be approved by the Town before being incorporated into the project.

9.03 Execution

A. General

The Contractor shall comply with all federal, state, and local erosion control laws.

B. Schedule

Prior to the start of construction, the Contractor shall submit schedules for accomplishing temporary and permanent erosion control work as applicable for clearing and grubbing, grading, construction, paving, and structures at watercourses. The Contractor shall also submit a proposed method of erosion and dust control on haul roads and borrow pits and a plan for disposal of waste materials. Work shall not be started until the erosion control schedules and methods of operations for the applicable construction have been accepted by the Town.

C. Authority of Town

The Town has the authority to limit the surface area of erodible earth material exposed by clearing and grubbing, to limit the surface area of erodible earth material exposed by excavation, borrow, and fill operations, and to direct the Contractor to provide immediate permanent or temporary control measures to minimize contamination of adjacent streams or other watercourses, lakes, ponds, or other areas of water impoundment.

D. Dust Control

Dust shall be minimized by the use of water. Dust control shall be practiced on a routine basis where conditions warrant. Watering and dust suppression shall be provided when requested by the Town.



E. Sediment Tracking

Public or private roadways shall be cleared of accumulated sediment that is a result of run-off or tracking. Bulk clearing of sediment shall be redistributed or disposed of in a manner that is in accordance with all applicable statutes and regulations.

F. Construction Details

The Contractor will be required to incorporate all permanent erosion control features into the project at the earliest practicable time as outlined in the accepted schedule. Except where future construction operations will damage slopes, the Contractor shall perform the permanent seedings and mulching and other specified slope protection work in stages as soon as substantial areas of exposed slopes can be made available. Temporary erosion and pollution control measures will be used to correct conditions that develop during construction that were not foreseen during the design state; that are needed prior to installation of permanent control features; or that are needed temporarily to control erosion that develops during normal construction practices but are not associated with permanent control features on the project.

Where erosion is likely to be a problem, clearing and grubbing operations should be scheduled and performed so that grading operations and permanent erosion control features can follow immediately thereafter if the project conditions permit; otherwise, temporary erosion control measures may be required between successive construction stages.

The Town will limit the area of clearing and grubbing, excavation, borrow, and embankment operations in progress, commensurate with the Contractor's capability and progress in keeping the finish grading, mulching, seeding, and other such permanent control measures current in accordance with the accepted schedule. Should seasonal limitations make such coordination unrealistic, temporary erosion control measures shall be taken immediately to the extent feasible and justified.

The Town may increase or decrease the area of erodible earth material to be exposed at one time as determined by analysis of project conditions.

The erosion control features installed by the Contractor shall be acceptably maintained by the Contractor during the construction period.



DESIGN AND CONSTRUCTION STANDARDS

Whenever construction equipment must cross watercourses at frequent intervals, and such crossings will adversely affect the sediment levels, temporary structures should be provided.

Pollutants such as fuels, lubricants, bitumen, raw sewage, wash water from concrete mixing operations (concrete washout), sediment-laden water from trench or pit dewatering, and other harmful materials shall not be discharged into or near rivers, streams, and impoundments or into natural or manmade channels leading thereto.

Pesticides shall not be applied when working in or adjacent to a river, stream, ditch, or other open storm water conveyance.

Unvegetated areas that are scheduled or likely to be left inactive for 7-days or more, must be temporarily or permanently stabilized with measures appropriate for the season to minimize erosion potential.

G. Inspections

If the project is regulated by IDEM's CSGP, the Contractor shall implement a self-monitoring program in accordance with the CSGP. If the project is not regulated by IDEM's CSGP, the Contractor shall implement an inspection program as described in this section.

All erosion control measures in place shall be inspected within 24-hours after any storm event greater than ½-inches or rain per 24-hour period.

The Contractor shall conduct a weekly inspection of the construction site to identify areas contributing to storm water discharges associated with construction activity.

Disturbed areas, material storage areas, and equipment storage areas that are exposed to precipitation shall be inspected on a regular basis for evidence of, or the potential for, pollutants entering the drainage system.

Storm water discharge locations shall be inspected to determine if erosion control measures are effective in preventing significant impacts to receiving waters.

Erosion control devices installed as specified shall be observed to ensure that they are operating properly.



DESIGN AND CONSTRUCTION STANDARDS

Haul routes and construction entrances to work areas shall be periodically inspected for evidence of off-site vehicle tracking of mud and dirt.

The Contractor's staging area shall be inspected to ensure that solid and liquid wastes are being properly disposed of and not allowed to be discharged into storm water run-off.

H. Inspection Reports

A report shall be completed summarizing the results of each inspection. The report shall include the name(s) and qualifications of personnel making the inspection, the date(s) of the inspection, major observations relating to the implementation of the erosion control plan, a certificate that the facility is in compliance with the plan, and identification of any incidents of noncompliance.

An inspection report form shall be used to record information obtained from field investigations of the erosion control measures. The record and certification shall be signed in accordance with the signatory requirements of the permit.

Inspection reports shall be maintained by the Contractor for 2-years following Town approval and acceptance of the project.

Reports must be made available to an inspecting authority within 48-hours of a request.

I. Maintenance

All erosion control measures shall be maintained throughout the project and until such time as the disturbed area has been completely stabilized or other provisions have altered the need for these measures.

The Contractor shall replace mulch materials to their original level when the level has been substantially reduced due to decomposition of the organic mulches and displacement or disappearance of both the organic and inorganic mulches.

Remove rubbish and channel obstructions from bare and vegetated channels within the project limits. The Contractor shall repair damage from scour or bank failure, rodent holes and breaching of diversion structures. Excessive wear, movement or failure of erosion control



DESIGN AND CONSTRUCTION STANDARDS

blankets shall be repaired immediately. Deposits of sediment shall be removed from the channel.

Repair any damage to silt fence barriers immediately and monitor barriers daily during prolonged rainfall.

Repair or replace any silt fence fabric which has decomposed or become ineffective prior to its expected usable life.

Remove sediment deposits after each storm event. Sediment must be removed when deposits reach approximately half the height of the silt fence barrier.

Till and smooth to conform with the existing grade and reseed any sediment deposits remaining in place after the silt fence barrier is no longer required.

Maintain the construction entrances in a condition to prevent tracking or flowing of sediment onto roads. This could require periodic top dressing with additional surface materials as conditions demand. Repair and clean out any features used to trap sediment and remove all sediment spilled, dropped, washed, or tracked on the roads and return to the point of likely origin.

Remove accumulated sediments and debris from inlet protection devices after each storm event.

Periodically remove concrete from the concrete washout area, as needed to maintain available space for the future washout.

All temporary erosion and sediment control practices shall be removed and disposed of within 30 days after site stabilization is achieved or after the temporary practices are no longer needed. Trapped sediment shall be permanently stabilized to prevent further erosion.

SECTION 10
INSPECTION, TESTING AND ACCEPTANCE
OF SANITARY SEWERS

<u>Section</u>	<u>Description</u>	<u>Page</u>
10.01	General.....	10-1
10.02	Inspection	10-1
10.03	Gravity Sewer Testing	10-2
	A. General	10-2
	B. Air Tests	10-2
	C. Infiltration Tests	10-3
	D. Exfiltration Tests	10-4
	E. Deflection Tests	10-4
10.04	Gravity Sewer Television Inspection	10-4
10.05	Force Main Testing	10-5
	A. General	10-5
	B. Hydrostatic Tests	10-6
	C. Leakage Tests.....	10-6
10.06	Manhole Vacuum Testing.....	10-7
10.07	Dedication and Acceptance Procedures	10-8
	A. Dedication	10-8
	B. Acceptance	10-8



SECTION 10

INSPECTION, TESTING AND ACCEPTANCE OF SANITARY SEWERS

10.01 General

This section describes the minimum requirements and general procedures for the inspection, testing, and acceptance of systems dedicated to the Town of Hebron.

10.02 Inspection

The Developer's Contractor shall test all manholes, gravity sewers, laterals, and force mains installed. New gravity sewers shall also be televised.

All necessary equipment and instrumentation required for proper completion of the flushing and testing of the manholes and piping systems shall be provided by the Contractor. Source and quality of water, test procedures, and disposal of water shall be approved by the Town.

All tests shall be made in the presence of the Town or its Agent. Preliminary tests made by the Contractor without being observed by the Town or its Agent will not be accepted. Notify the Town at least 48 hours before any work is to be inspected or tested.

All defects in piping systems shall be repaired and/or replaced and retested until they are found to be acceptable to the Town. Repairs shall be made to the standard of quality specified for the entire system.

Sections of the system may be tested separately, but any defect which may develop in a section previously tested and accepted shall be promptly corrected and retested.

All manholes and piping systems shall be tested in accordance with these test methods in addition to any test required by the IDEM, State or Local plumbing codes, and/or building authorities.



10.03 Gravity Sewer Testing

A. General

After backfill has been placed, the Town will visually inspect all gravity flow lines to check alignment and grade. All obstructions shall be removed. Any sewer in which the direct light of a lamp cannot be viewed in either direction between adjacent manholes shall be considered unsatisfactory and shall be repaired by the Contractor immediately.

Unless otherwise directed by the Town, all underground sewer system piping for gravity flow shall be subjected to an air test rather than an infiltration or exfiltration tests, however, infiltration and exfiltration test methods may be requested by the Town during construction. When leakage occurs in excess of the specified limits, defective pipe or joints shall be located and repaired. The Contractor shall remove and reconstruct, along with retesting, as much of the original work as necessary to obtain a sewer test within the allowable leakage limits.

B. Air Tests

Air tests shall be per ASTM F1417, standard test method for installation acceptance of plastic gravity sewer lines using low pressure air, latest revision. The sewer line to be tested shall be tested in increments between manholes. The line shall be sealed at each end. The seal at one end shall have an orifice through which to pass air into the pipe. An air supply shall be connected to the orifice at one end of the line. The air supply line shall contain an on/off gas valve and a pressure gauge having a range of 0 to 5 psi. The gauge shall have minimum divisions of 0.10 psi and shall have an accuracy of ± 0.04 psi.

The pipe line under test shall be pressurized to 4 psig. The line shall be allowed to stabilize between 4 psig and 3.5 psig for a period of no less than 5 minutes. If necessary, air shall be added to the line to maintain the pressure above 3.5 psig. After the stabilization period, the gas valve shall be closed. When the line pressure drops to 3.5 psig, commence timing with a stop watch. The stop watch shall be allowed to run until such time as the line pressure drops to 2.5 psig. If the test time is greater than the allowable time for 1.0 psig pressure drop, the test section will have passed the pressure test.

Allowable times are shown in the following table.



DESIGN AND CONSTRUCTION STANDARDS

Minimum Specified Time Required for a 1.0 psig Pressure Drop For Size and Length of Pipe Indicated, Q=0.0015

Pipe Dia. (in)	Min. Time (min:s)	Length for Min. Time (ft)	Time for Longer Length (sec)	Specification Time for Length (L) Shown, minutes							
				100 ft	150 ft	200 ft	250 ft	300 ft	350 ft	400 ft	450 ft
4	3:46	597	0.380 L	3:46	3:46	3:46	3:46	3:46	3:46	3:46	3:46
6	5:40	398	0.864 L	5:40	5:40	5:40	5:40	5:40	5:40	5:42	6:24
8	7:34	298	1.520 L	7:34	7:34	7:34	7:34	7:36	8:52	10:08	11:24
10	9:26	239	2.374 L	9:26	9:26	9:26	9:53	11:52	13:51	15:49	17:48
12	11:20	189	3.418 L	11:20	11:20	11:20	14:15	17:05	19:56	22:47	25:38
15	14:10	159	5.342 L	14:10	14:10	17:48	22:15	26:42	31:09	35:36	40:04
18	17:00	133	7.692 L	17:00	19:13	25:38	32:03	38:27	44:52	51:16	57:41
21	19:50	114	10.470 L	19:50	26:10	34:54	43:37	52:21	61:00	69:48	78:31
24	22:40	99	13.574 L	22:47	34:11	45:34	56:58	66:22	79:45	91:10	102:33
27	25:30	88	17.306 L	28:51	43:16	57:41	72:07	86:32	100:57	115:22	129:48
30	28:20	80	21.366 L	35:37	53:25	71:16	89:02	106:50	124:38	142:26	160:15
33	21:10	72	26.852 L	43:06	64:38	86:10	107:48	129:16	150:43	172:21	193:53
36	34:00	66	30.768 L	51:17	76:55	102:34	128:12	153:50	179:29	205:07	230:46

If the time lapse is greater than that specified, the section undergoing tests shall have passed. If the time is less than that specified, the line has not passed the test and the Contractor shall be required to make all repairs and retests. If the pipe line to be tested is beneath the ground water level, the test pressure shall be increased 0.433 psi for each foot the ground water level is above the crown of the pipe.

The Contractor shall furnish all equipment and personnel required to make all tests including pipe stoppers, air compressor, air storage tank, pressure regulating valves, pressure gauges, stopwatch, etc. The Contractor shall take all precautions necessary, including blocking of stoppers or plugs, to protect the safety of property and personnel.

C. Infiltration Tests

When the groundwater level is 4-feet or more above the top of the sewer, the infiltration test will consist of sealing off a length of sewer and measuring the depth of flow over a measuring weir, or by pumping the infiltrated water into containers for measurement. Tests shall be conducted for a minimum of 4-hours. Infiltration leakage shall not exceed 200 gallons per 24 hours per inch diameter, per mile of sewer.



D. Exfiltration Tests

When the groundwater level is below a point 4-feet above the top of the pipe, the exfiltration test shall consist of isolating the particular section and filling the water to a point 4-feet above the ground water level in the upper manhole and allowing it to stand not less than 4-hours. The section shall then be refilled with water up to the original point and after 2-hours the drop in water surface shall be measured. The computed leakage shall not exceed 200 gallons per inch diameter, per 24 hours, per mile of sewer.

E. Deflection Tests

Deflection tests shall be performed on all flexible pipes after the final backfill has been in place at least 30 days. No pipe shall exceed a vertical deflection of 5%. Deflection testing shall be performed using a mandrel pulled by hand.

Ductile iron pipe is considered non-flexible and will not require a deflection test.

10.04 Gravity Sewer Television Inspection

A. After new gravity sanitary sewers have been completed and all sewers have passed the required testing, new segments shall be internally inspected, via closed circuit television (CCTV) inspection, by the Developer. These inspections shall be recorded on USB flash drive(s), including a narrative noting:

1. Date and time of day.
2. Sewer segment number "from manhole to manhole".
3. Locations of service connections (laterals) into sewer.
4. If detected, the location of obstructions, structural defects, leakage, or evidence thereof, and other abnormalities with respect to the sewer condition and distance in feet from the upstream manhole centerline.

B. The video shall visually display date, pipe section number (manhole number) and distance from upstream manhole (accuracy of 2-feet±). Where an obstruction is encountered and a reverse set up is required, the distance shall be written and verbally noted on the video as to from which manhole measurements are being made. Video case shall display the same information as indicated above plus date and crew ID number. Videos of all sections shall be provided to the Town along with the



DESIGN AND CONSTRUCTION STANDARDS

respective television inspection field logs. TV field logs shall legibly show the location of each point of significance in relation to an identified manhole, including private service connections (laterals).

- C. Video shall be a continuous image of not less than ninety percent (90%) of the internal pipe surface at all times. Maximum acceptable speed of camera through sewer shall be 30-feet per minute. Lighting system shall be adequate for quality pictures. A reflection in front of the camera may be required to enhance lighting.
- D. If any obstruction in the sewer segment prohibits the passage of the television camera, Contractor shall inspect the remainder of the sewer segments by making a reverse set up at the next down stream manhole.
- E. All obstructions in the sewer segment that prohibit passage of the television camera shall be immediately reported to the Town by Contractor referencing location and nature of the obstruction.
- F. The video camera shall be equipped with remote control devices to adjust the light intensity and a minimum 1,000-feet of continuous cable shall be provided. The camera shall be able to transmit a continuous image to the television monitor as it is being pulled through the sewer segments.
- G. Developer shall submit the original video files on a USB flash drive, along with corresponding written televising log sheets, to the Town for review at the conclusion of the project and prior to acceptance of the sewers.

10.05 Force Main Testing

A. General

All sewage force mains shall pass a hydrostatic pressure test as specified. All buried piping with slip-type or mechanical joints shall pass a leakage test. No leakage is allowed in exposed piping or buried piping with flanged, threaded, welded, or mechanical joints.

Tests for exposed piping shall be made before covering and insulation is placed and prior to concealment within the building or lift station construction.

The pressure and leakage tests for buried piping shall be made after all jointing operations and backfilling are completed and concrete reaction



DESIGN AND CONSTRUCTION STANDARDS

blocks and restraints have cured at least 14 days. Piping tested before backfill is in place shall be retested after compacted backfill is placed.

Sections of piping between valves and other short sections of line may be isolated for testing. If shorter sections are tested, test plugs or bulkheads required at the ends of the test section shall be furnished and installed by the Contractor, together with all anchors, braces, and other devices required to withstand the hydrostatic pressure without imposing any thrust on the pipeline. The Contractor shall be solely responsible for any damage which may result from the failure of test plugs or supports.

B. Hydrostatic Tests

Piping systems shall be slowly filled with water and all air expelled from the pipe. Care shall be taken that all air valves are installed and open in the section being filled and that the rate of filling does not exceed the venting capacity of the air valves. After the section of line to be tested has been filled with water, the specified test pressure shall be applied and maintained for a minimum period of 2-hours and for such additional period as necessary for the Town to complete the inspection of the line under test. If defects are noted, repairs shall be made, and the test repeated until all parts of the line withstand the test pressure. Hydrostatic test pressures shall be 150% of the design pressure, but not less than 50 psi. Test duration shall be 2-hours.

C. Leakage Test

After the specified hydrostatic test has been completed, the line shall be subjected to leakage test under a hydrostatic pressure the same as the pressure specified for the hydrostatic test. The pressure shall be maintained within a maximum variation of 5% during the entire leakage test. Leakage measurements shall not be started until a constant test pressure has been established. The line leakage shall be measured by means of a water meter installed on the supply side of the pressure pump, or method as approved by the Town.



DESIGN AND CONSTRUCTION STANDARDS

The tested section will not be accepted if it has a leakage rate in excess of that rate determined by the formula:

$$L = \frac{0.000135 \times N \times D \times P}{2}$$

where:

- L = Maximum permissible leakage rate, in gallons per hour, throughout the entire length of line being tested
- N = Number of gasketed joints (2 for each flexible coupling joint) in the line under the test
- D = Nominal internal diameter (in inches) of the pipe
- P = The actual pressure in psig on all joints in the tested portion of the line. This actual pressure shall be determined by finding the difference between the average elevation of all tested pipes joints and the elevation of the pressure gauge and adding the difference in elevation head to the required pressure.

Where the leakage rate exceeds the permissible maximum, the Contractor shall locate and repair leaking joints to the extent required to reduce the total leakage to the required amount.

All leaks discovered within 1-year from the date of final acceptance of the work by the Town shall be located, repaired, and retested by the Contractor, regardless of the total line leakage rate.

10.06 Manhole Vacuum Testing

Manholes shall be air tested in accordance with ASTM C1244, "Standard Test Method for Concrete Sewer Manholes by the Negative Air Pressure (Vacuum) Test".

The equipment required to conduct a vacuum test on manholes includes inflatable pipe plugs, test head, vacuum pump, flexible air hose, and a vacuum gage. The test equipment shall be capable of drawing a vacuum of 10-inches mercury (Hg). The equipment shall be designed specifically for the purpose of testing manholes and shall be as manufactured by P.A. Glazier, Inc., Worcester, Massachusetts, 10002 or as approved by the Town.



DESIGN AND CONSTRUCTION STANDARDS

The procedure for conducting an air test on manholes shall be in accordance with the following procedure:

- Each manhole shall be tested immediately after assembly and prior to setting the casting or backfilling around the structure.
- All lift holes shall be plugged with non-shrink grout.
- All pipes entering the manhole shall be securely plugged and adequately braced against the inside of the manhole to prevent being drawn out of the pipe.
- The test head shall be placed on the inside of the cone section and sealed with an inflatable seal.
- A vacuum of 10-inches of mercury (Hg) shall be drawn before the vacuum pump is shut off. With the valves closed, the time shall be measure for the vacuum to drop to 9-inches. The manhole shall pass if the time is greater than the following:

Depth	Diameter		
	48"	60"	72"
Time in seconds			
8	20	26	33
10	25	33	41
12	30	39	49
14	35	46	57
16	40	52	67
18	45	59	73
20	50	65	81
22	55	72	89
24	59	78	97

10.07 Dedication and Acceptance Procedures

A. Dedication

The Town Engineer shall review the applicable requirements and prepare a document stating that the work has been completed, the requirements have been met, and all items are in proper form. The Town Engineer shall include in the statement a recommendation on acceptance/denial of the



DESIGN AND CONSTRUCTION STANDARDS

facilities and may also include comments regarding the project. The Town Engineer shall present to the Planning Administrator its findings for consideration.

B. Acceptance of Facilities

The Town will assume responsibility of the sanitary sewer when construction is fully completed in accordance with the plans and specifications and when all requirements in these Design and Construction Standards are met.

The Town shall receive the recommendation from the Town Engineer, and upon review by the Planning Administrator, shall make a determination as to acceptance of the facilities.

Sewer taps will not be issued until the facilities are accepted by the Town.

SECTION 11

Fats, Oils & Grease (FOG) Requirements

<u>Section</u>	<u>Description</u>	<u>Page</u>
11.01	Required Treatment for FOG	11-1
11.02	FOG Facility Requirements	11-1
11.03	FOG Inspections	11-2
11.04	Enforcement	11-3



SECTION 11

INSPECTION, TESTING AND ACCEPTANCE

OF SANITARY SEWERS

11.01 Required Treatment for FOG

Users shall be required to provide pretreatment for fats, oils, and grease (FOG) at all new, renovated, and reconstructed restaurants and food service establishments which may include industrial, institutional, or commercial enterprises when, in the opinion of the Town, the facility has the potential to discharge FOG in concentrations deemed potentially detrimental to the Town's sewage works or POTW. Users whose facilities are required to install FOG equipment shall be referred to herein as a "FOG facility" or "FOG facilities".

11.02 FOG Facility Requirements

- a) All FOG facilities shall:
 - a. Properly install a FOG pretreatment device that is acceptable to the Town and in accordance with the Sewer Use Ordinance and these Standards.
 - b. Maintain FOG pretreatment device as directed by the Town at the User's expense.
 - c. Operate the device in compliance with the Town's prohibited discharge requirements.
 - d. Be approved to operate and maintain an existing FOG pretreatment device provided these are in proper operating condition as set forth with the Sewer Use Ordinance and these Standards.
 - e. Assume all responsibility in the sizing, plumbing configuration of the FOG pretreatment device and be responsible for what is or is not plumbed into its FOG pretreatment device.
 - f. Locate the FOG pretreatment devices in easily accessible areas for inspection by the Town and for proper maintenance by the user.
- b) *Properly Operating FOG Equipment.* If the facility does not have plumbing connections to a FOG pretreatment device that functions to bring the user in compliance with the requirements of the Town, the facility shall modify their current plumbing to prevent the introduction of FOG into the sewer.



DESIGN AND CONSTRUCTION STANDARDS

- a. A grease interceptor shall have a capacity of at least 1,000 gallons to serve one or more fixtures and shall be located outside the building.
- b. A maximum of four (4) fixtures shall be connected to a grease trap.
- c) *Operations and Maintenance.* The User of a grease interceptor, grease trap, and/or oil/water separator shall operate, service, and clean FOG equipment per the manufacturer's instructions to prevent the introduction of prohibited discharges to the sewage works and POTW. The User shall not allow waste/water to be returned to the apparatus once pumped. Additionally, the User is responsible for properly training and requiring its staff to dispose of grease and waste, so it is not reintroduced back into the sewage works.
- d) Recordkeeping. All users shall provide, on demand, to the Town, sufficient information for the Town to determine if the user is a FOG facility. Users shall retain maintenance records for three (3) years on a continuously rolling calendar. All such records shall be available for inspection by the Town. User shall report to the Town, in writing, any discharge within twenty-four (24) hours of event.
- e) Changes in Occupation or Ownership. Any change in ownership of a FOG facility will be recognized as a new FOG facility and shall comply with the Town's prohibited discharges in accordance with this Ordinance. In the event the occupant changes, building usage changes, and/or new construction occurs upon any FOG facility, and/or where a change in occupancy, change in building usage, and or new construction would cause a non-FOG facility to become a FOG facility, the User shall notify the Town, in writing, of the changes within thirty (30) days of the date the change takes place.

11.03 FOG Inspections

- a) At the Town's discretion, FOG pretreatment devices may be inspected by the Town to assure compliance with this ordinance. Any Town official or agent of the Town bearing proper identification shall be granted access to all parts of the premises of a FOG facility for the purpose of inspection, observation, record examination, measurement, sampling, and testing.
- b) It is the responsibility and obligation of the User of the FOG facility to open the pretreatment device to allow the Town access for inspections.
- c) The refusal of any FOG facility to allow the Town official or agent entry to or upon the FOG facility's premises for purposes of inspection, sampling effluents, inspecting, copying records, and/or performing other such duties by this



DESIGN AND CONSTRUCTION STANDARDS

ordinance shall constitute a violation of this Ordinance. The Town's official may inspect FOG facilities during both scheduled and unscheduled visits.

11.04 Enforcement

Enforcement actions for this section shall conform to the enforcement actions described in the Sewer Use Ordinance.

APPENDIX A

STANDARD FORMS FOR SANITARY SEWER SERVICE

APPENDIX A
STANDARD FORMS FOR SANITARY SEWER SERVICE

<u>Title</u>	<u>Form No.</u>
Instructions on Application For The Provision of Sanitary Sewer Service to Areas Outside the Town of Hebron	1
Agreement for Private Construction of a Sanitary Sewer and Provision of Municipal Sewer Service	2
Dedication of Sanitary Sewer Lines	3
Agreement Not to Remonstrate Against Annexation	4
Agreement for the Oversizing of a Sanitary Sewer Line	5

These forms and their provisions are subject to revision by the Town of Hebron at any time. Other documents not included in this appendix may be required by the Town of Hebron.

FORM NO. 1

INSTRUCTIONS ON APPLICATION FOR THE PROVISION OF SANITARY SEWER SERVICE TO AREAS OUTSIDE THE TOWN OF HEBRON

APPLICATION PROCESS

In order for the Town to determine how and when it can provide sewer service to property in this Service Area, and what connection fees and the developer's share of the costs for the extension of the sewer line to the property will be, certain information must be provided to the Town. Most, if not all, of the information needed by the Town should be obtainable from the documents that are listed below as Required Submittal Documents. For some service requests, the Town may determine that information in addition to the below listed documents, such as engineering studies, is needed in order for the Town to have a complete application to review. The Town may require the applicant to provide such additional information or may arrange to obtain such information from other sources and include the costs for producing that information in assessment of the application review fee. Once the Town receives all the required information and documents (in form and detail acceptable to the Town), it will need 30 to 60 days, to make its determinations on how and when sewer service can be extended, what connection fees will be required and what the developer's share of the costs for the extension of the sewer line to the property will be. If the developer chooses to negotiate with the Town on the arrangements for the extension of the sewer line to the property, the 30 to 60 days determination period will not commence until the negotiation process has been completed. Also, if and when any material changes are made in the information and documents submitted with the application, 30 to 60 days from the time the Town receives revised submittal information and documents may be required for the determination.

Once the Town has made these determinations and the applicant has paid the required application review and connection fees, or the provided a bond assuring payment of such fees, and a binding agreement to pay its share of the costs for the extension of the sewer line to its property, the application will be considered as complete and as having been received by the Town at that time. If material changes are made in the development that would affect the arrangements the Town has made or approved for the extension of a sewer line to the property or applicant's commitment to timely pay its determined share of the costs for the extension of the sewer line to its property, a new application and review fee may be required.

REQUIRED SUBMITTAL DOCUMENTS

1. USGS topographic quadrangle map at 2000 scale showing the location of the property to receive sewer service, including perimeter boundaries of the property drawn to scale.
2. Detailed sketch plan of the proposed development on the property with sufficient information on number and type of structures to allow a determination of the expected volume of sewer usage in accordance with Town standards.

FORM NO. 1

3. A schedule for construction of the development, indicating timing of completion each building or group of buildings (if done construction is planned in separate phases).
4. Identification of all other utilities providing or anticipated to provide services to the property.
5. Identification of any contingencies that may alter, delay, or prevent the development of the property in accordance with the plans submitted.

APPLICATION FEES AND DEVELOPER'S SHARE OF SEWER LINE EXTENSION COSTS

1. The Town will not commence its review of the required submittal documents until payment is made of an application review fee. This fee is intended to cover the Town's costs for the professional services required to review the submittals and to perform analysis to enable the Town to make its determination on how and when it can provide sewer service to property, and what connection fees and the developer's share of the costs for the extension of the sewer line to the property will be. This fee may also include the cost of producing information in addition to the above listed Required Submittal Documents, such as engineering studies, that the Town determines is needed in order to have a complete application to review. Unless and until the Town fixes a fee or establishes a formula for the imposition of the application review fee, the amount of this fee shall be determined by the Town as soon as it has sufficient preliminary information about the applicant's expected sewer needs to determine the Town's costs for doing its review of the application.
2. Connection charges are based on the number of equivalent dwelling units (EDUs) a building or development is projected to have. Each EDU is equal to the average amount of daily sanitary sewage flow for an average single-family residence which flow has been determined to be 310 gallons per day.
[note: By accepting a payment of connection fees the Town guarantees the availability of sewer system capacity for the volume of connections paid. Discounted rates are applicable to large volume payment of connection fees.]
3. Applicant's share of the costs for the extension of the sewer line to its property are those costs that may be charged for the extension of sewer service as sewer interceptor costs under the Town's sewer rate ordinance and other costs that may be associated with the extension of sewer services between a sewer interceptor or an existing sewer line and the property. An agreement by the applicant to pay its share of the costs for the extension of the sewer line to the property may be in the form of payment of identified sewer interceptor fees; bonding for the payment of sewer interceptor fees and the other costs that may be associated with the extension of sewer services between a sewer interceptor or an existing sewer line and the property; and/or a contract to build or pay for applicant's assigned share of a sewer extension.

APPLICANT RESPONSIBILITIES

FORM NO. 1

1. Submission of a letter indicating applicant has received and reviewed these instructions and agrees to fulfill all Applicant Responsibilities or will voluntarily withdraw the request for sewer service.
2. Provide complete and accurate information in the Required Submittal Documents and timely notify the Town of any changes in the information contained in these documents.
3. Pay all application review, connection and interceptor fees; enter into any needed agreements regarding the extension of a sewer line to the property; and fulfill the terms of all agreements entered into.
4. Complete the Town's forms waiving property owner rights to remonstrate or otherwise challenge any future Town effort to annex the property; submit these completed forms with the sewer service application; and ensure that these are properly recorded so as to be binding on future owners of all parts of the property.
5. After the application is accepted, provide the Town with internal development sewer design plans that are in compliance with Town standards and pay the Town the required fees for the review of those plans.
[note: this information is needed by the Town for it to make its capacity certification to IDEM which IDEM uses to issue a construction permit to the developer.]
6. Submittal of all sewer easement documents in a form acceptable to the Town.
7. For any lines that are not internal to the lot they serve, applicant shall provide an agreement to dedicate those lines to the Town that is acceptable to the Town or an agreement establishing who will be responsible for the operation and maintenance of the sewer lines.
8. Cooperate in the Town's inspection of the installation of the sewer system internal to the property and pay the Town the required fees for the inspection services.

TOWN RESPONSIBILITIES

1. Timely review and make determinations on applicant's request for sewer service following the process described above.
2. Upon making its determinations and receiving payment of the appropriate connection fees, to reserve sewer system capacity for the applicant in accordance with Town policies regarding the pre-purchase of connections fees.
3. Permit connection to the Town's sewer system provided the application for service has been accepted by the Town and applicant has fulfilled all its responsibilities.
4. If applicant installs or pays the entire cost of a sewer line external to his property using a recoupment procedure approved by the Town, the Town will support the process for the recoupment of appropriate portions of those costs from future connections to that sewer line to other properties.

FORM NO. 2

**AGREEMENT FOR PRIVATE CONSTRUCTION OF A SANITARY
SEWER AND PROVISION OF MUNICIPAL SEWER SERVICE**

This Agreement made and entered into this _____ day of _____, 20 ____,
by and between (“OWNER’S NAME AND MAILING ADDRESS”) and the Town of
Hebron, Indiana (“TOWN”);

WITNESSETH THAT:

WHEREAS, OWNER has requested permission to construct under Private Contract a
sanitary sewer described under Paragraph 1 of this Agreement, and to connect the
sanitary sewer to TOWN’S Public Sewer System, all work to be done at OWNER’S
expense; and

WHEREAS, TOWN is willing to grant its permission for the construction and connection
of the sanitary sewer by OWNER and at OWNER’S expense upon the terms and
conditions hereinafter set forth; and

NOW, THEREFORE, it is agreed among the parties as follows:

1. Upon payment of a connection charge in the sum of \$ _____ by
OWNER to TOWN, the receipt of which is hereby acknowledged, OWNER is
authorized to construct at OWNER’S sole expense a sanitary sewer located and more
particularly described as follows, to wit: _____

_____ and to connect the sanitary sewer to TOWN’S sewer system at
_____.

2. Such construction and connection shall be made in strict accordance with the plans
approved by TOWN under date of _____, 20 ____, the standard
specifications of TOWN pertaining to sanitary sewer construction and all other
applicable laws, rules and regulations. Said plans, specifications, code and all other
applicable laws, rules and regulations are made a part of this Agreement by reference.
Such construction and connection shall be subject at all times to the inspection,
approval, and acceptance of TOWN.
3. All excavations over which pavement, curbs, or walks are to be built or replaced
within six (6) months after the backfilling thereof, shall be backfilled with granular
material as directed by TOWN or other proper governmental authority.
4. It is understood by the parties that this sewer, and the connection thereto, shall be
used only for and as a sanitary sewer. No stormwater, runoff water, downspouts,
footing drains (perimeter drains) or sub-soil drainage shall be connected to this
sanitary sewer. Any dewatering necessary in connection with the construction of this
sewer shall be done in accordance with the standard specifications of TOWN, and all
other applicable laws, rules and regulations.

FORM NO. 2

5. OWNER shall pursue the construction of the sanitary sewer without delay to final completion.
6. No liability of any kind for any part of the sanitary sewer shall attach to TOWN. OWNER shall indemnify and hold TOWN harmless against all claims, demands, actions, causes of action, loss and expense of every nature and kind (including attorney's fees) at any time asserted against TOWN for or on account of any person, arising out of, or in any way connected with, the location, installation and construction of the sanitary sewer. This indemnity shall not be limited by reason of the enumeration of any insurance coverage required herein. Prior to the commencement of the construction authorized by this Agreement, OWNER shall furnish to TOWN evidence of a public liability insurance policy in the minimum amount of One Hundred Thousand Dollars (\$100,000.00), each occurrence, Three Hundred Thousand Dollars (\$300,000.00), each aggregate, for bodily injury limits, and Fifty Thousand Dollars (\$50,000.00), each occurrence, One Hundred Thousand Dollars (\$100,000.00), each aggregate, for property damage limits.
7. Prior to the commencement of construction, OWNER shall furnish a suitable irrevocable letter of credit or guarantee construction bond made payable to the Town of Hebron with good and sufficient surety thereon, conditioned on the performance by OWNER of the obligations set forth under this Agreement. In lieu of the bond or letter of credit, OWNER may pay the sum of \$ _____ to the Town of Hebron as nonrefundable performance security.
8. OWNER shall also, in the event any part of the sanitary sewer is to be constructed across, over, on, through or under any public highway or right-of-way, furnish TOWN suitable evidence of authority to do so, in a form acceptable to TOWN, procured from the proper governmental agency having jurisdiction and control over such public right-of-way. All necessary easements and related instruments pertaining to privately-owned property shall also be in a form acceptable to TOWN.
9. The parties agree that inspection of the sanitary sewer construction shall be handled in the following manner:
 - a. At OWNER'S expense, TOWN shall provide Contract Inspection Services during the construction of the sanitary sewer to determine whether the sewer is constructed in accordance with approved plans and specifications.
 - b. Such Inspection Services shall not include construction engineering or construction stake out. OWNER or his designated representative shall be solely responsible for the performance of construction engineering and stake out and all construction work.

FORM NO. 2

- c. OWNER shall notify the assigned INSPECTING ENGINEER at least seventy-two (72) hours in advance of the commencement of each of the following construction phases:
 - 1) Installation of Sanitary Sewers, Manholes and Lift Station;
 - 2) Backfilling of Sanitary Sewers; and
 - 3) Testing of Sanitary Sewers.
 - d. Persons working on or having control of the construction of the sanitary sewer shall cooperate fully with the INSPECTING ENGINEER and shall have available on site a copy of the approved plans and specifications used to obtain the construction permit.
 - e. OWNER shall reimburse INSPECTING ENGINEER for the cost of the Inspection Services as follows: _____ dollars (\$____) per hour of actual time spent on the project by the assigned INSPECTING ENGINEER performing the Inspection Services.
 - f. Under this Agreement, the total cost of the inspection services is based upon an average estimated time of thirty (30) hours per week per construction crew per project on each of the phases of construction set forth above, with the hourly rate set forth above.
 - g. OWNER must submit the balance of the total cost of the Inspection Services to INSPECTING ENGINEER prior to acceptance of the sanitary sewer system by TOWN.
 - h. Failure to follow the requirements of this Section 9 may result in TOWN not accepting the sanitary sewer and denying a sanitary sewer connection permit.
10. Upon completion of the proposed sanitary sewer, a set of “as built” tracings including all house connection measurements shall be prepared by OWNER and filed with TOWN, before such sewer will be accepted into TOWN’s Sewer System.
11. Upon completion of the proposed sanitary sewer, CONTRACTOR shall furnish a completion affidavit in a form prescribed by TOWN, and CONTRACTOR or OWNER shall also furnish a suitable irrevocable letter of credit or guarantee maintenance bond made payable to the TOWN of Hebron with good and sufficient surety thereon and acceptable to TOWN in an amount not to exceed twenty percent (20%) of the total contract price for said improvement. The letter of credit or bond shall be in the form required by TOWN and shall guarantee material and construction for a period of three (3) years from the date of final acceptance.
12. After approval and acceptance by TOWN, the sanitary sewer shall become a part of the public sanitary sewer system of TOWN with title vested in TOWN and shall be thereafter under full control, authority and jurisdiction of TOWN, to the same extent

FORM NO. 2

and in the same manner as though the sewer had been originally constructed by TOWN under a Public Improvement Contract.

IN WITNESS WHEREOF, the parties acting by and through their authorized representatives have executed this instrument on the day and year first above written, and affirm that no unauthorized alterations of this document have taken place.

OWNER:

NAME OF COMPANY (IF APPLICABLE)

SIGNATURE (OF OFFICER)

PRINTED NAME & TITLE

STATE OF INDIANA)
) SS:
COUNTY OF MARION)

BEFORE ME, the undersigned, a Notary Public in and for said County and State, personally appeared _____, and acknowledged the execution of the foregoing Agreement to be his/her free and voluntary act and deed.

WITNESS my hand and Notarial seal this _____ day of 20 ____.

COUNTY OF RESIDENCE SIGNATURE

COMMISSION EXPIRATION DATE PRINTED NAME

TOWN OF HEBRON:

SIGNATURE (OF OFFICER)

PRINTED NAME & TITLE

ATTEST:

Hebron Clerk-Treasurer

FORM NO. 3

DEDICATION OF SANITARY SEWER LINES

WHEREAS, _____, as the owner of certain real estate in Hebron, Indiana (hereinafter referred to as Grantor), caused to be constructed originally sanitary sewer lines and appurtenances thereto, which are shown upon plans and specifications now on file with the Town of Hebron (hereinafter referred to as Grantee); and

WHEREAS, Grantor desires to and has agreed to transfer and dedicate to Grantee said sanitary sewer lines and appurtenances without cost or charge to Grantee and in consideration thereof, Grantee has agreed to accept said dedication, and to thereafter supervise and maintain said sewer lines and appurtenances.

NOW, THEREFORE, in consideration of the promises set forth in the foregoing recitals, but without payment of cash consideration, Grantor does hereby grant, transfer, assign, and dedicate to Grantee all the sanitary sewer lines and appurtenances located and described as follows:

Grantor represents that it is the lawful owner of all of the sewers and appurtenances (and exceptions) hereby transferred and dedicated, and that it has the right to transfer title to all of the property hereby transferred and dedicated to Grantee.

Grantor further represents that all of the sewers and appurtenances hereby transferred and dedicated, have been completely and properly constructed and installed, have passed all required inspections and tests and are ready for service as a part of the Hebron sanitary sewer collection system.

Grantee accepts the dedication and transfer hereby evidenced and agrees that it will hereafter supervise and maintain said sewer lines and appurtenances, excepting, however, the laterals from the main line to the adjacent properties as a part of its sanitary sewer collection system.

IN WITNESS WHEREOF, Grantor has executed or caused to be executed this instrument this _____ day of _____, 20 ____.

GRANTOR

SIGNATURE AND TITLE

PRINTED

FORM NO. 3

STATE OF INDIANA)
) SS:
COUNTY OF MARION)

BEFORE ME, the undersigned, a Notary Public in and for said County and State, personally appeared _____, and acknowledged the execution of the foregoing Agreement to be his/her free and voluntary act and deed.

WITNESS my hand and Notarial seal this _____ day of 20 ____.

COUNTY OF RESIDENCE SIGNATURE

COMMISSION EXPIRATION DATE PRINTED NAME

DEDICATION ACCEPTED BY TOWN OF HEBRON:

SIGNATURE (OF OFFICER)

PRINTED NAME & TITLE

ATTEST:

Hebron Clerk-Treasurer

FORM NO. 4

AGREEMENT NOT TO REMONSTRATE AGAINST ANNEXATION

The undersigned represents that they are sole owners of certain real estate located in Porter County, Indiana, which is commonly know by the address of _____ and more specifically identified by the attached map or legal description.

As partial consideration for the Town of Hebron’s agreement to allow buildings on this real estate to connect to the Town’s sanitary sewer collection system, the undersigned property owners agree to release their rights, and those of any successors or assigns, to remonstrate or take any other action to oppose any future annexation of this real estate by the Town of Hebron. The undersigned property owners further agree to sign and provided continued support to a voluntary petition for annexation, and should this not be done now, owners agree to do this when officials of the Town of Hebron request their signatures and support for such annexation petition.

Executed this _____ day of _____, 20__.

Owner

Owner

STATE OF INDIANA)
) SS:
COUNTY OF MARION)

BEFORE ME, the undersigned, a Notary Public in and for said County and State, personally appeared _____, and acknowledged the execution of the foregoing Agreement to be their free and voluntary act and deed.

WITNESS my hand and Notarial seal this _____ day of 20__.

COUNTY OF RESIDENCE SIGNATURE

COMMISSION EXPIRATION DATE PRINTED NAME

FORM NO. 5

AGREEMENT FOR THE OVERSIZING OF A SANITARY SEWER LINE

WHEREAS, _____ (the Developer) is developing a new residential subdivision called _____ (the Development) which is to receive sanitary sewer service from the Town of Hebron (the Town), and

WHEREAS, in accordance with the Town's policy regarding the extension of sewer service, the Developer is responsible for construction of sewer lines needed to connect their development to the Town's sanitary sewer collection system, and

WHEREAS, a sewer line with a diameter of _____ inches buried at a sufficient depth to transport by gravity sewage from dwelling units in the Development would be needed to provide sewer service to this development only, and

WHEREAS, the Town has determined that it would be useful to the Town for the Developer to construct a larger sewer line of _____ inches buried at a sufficient depth to be a collector line also serving other dwelling units anticipated to be built in the future outside of, but in proximity to, the Development, and

WHEREAS, the construction of this "oversized" sewer line is expected to cost significantly more than the construction of a sewer line sufficient to serve the Development only, and

WHEREAS, the Town has offered the Developer arrangements whereby the Developer can recoup additional expenses for constructing the "oversized" sewer line, i.e. expenses in excess of that required for a _____ inch line which would serve only the Development.

NOW THEREFORE, in consideration of the Developer's agreement to build an "oversized" sanitary sewer line of _____ inches in accordance with plans and specifications approved by the Town, the Town will compensate the Developer pursuant to the following arrangement:

1. The Developer will secure from the contractor it has engaged to construct the sewer line (the Contractor) detailed cost projections for both the construction of a sewer line of _____ inches buried at a sufficient depth to serve only those dwelling units in the Development and for a sewer line of _____ inches buried at a sufficient depth, as approved by the Town's engineer, to serve other dwelling units anticipated to be built in the future in the proximity.
2. These cost projections will be submitted to the Town for review by its engineer to determine whether the cost projections appear to be based on reasonable determinations of the costs for the construction of those lines. If the Town's engineer determines that the cost estimates are not based on

FORM NO. 5

reasonable determinations, he will prepare a fair and reasonable determination of the costs with supporting data and/or other justification for his determination.

3. Within thirty 30 days of its receipt of complete cost projections from the Developer, the Town shall notify Developer of the dollar amount it will allow the Developer to recoup from the Town for oversizing the sewer line through the conveyance of connection fee credits for individual dwelling units within the Development (these fees are currently set at \$3,100 per unit).
4. The Developer shall receive the connection fee credits, and will be considered as having satisfied its obligation to the Town for all interceptor fees, when the Town has conducted its final inspection of the sewer line and has approved the completed line. If the sewer line is not completed the Developer shall not receive the connection fee credits. If the sewer line is not constructed in accordance with plans and specifications approved by the Town, the Developer shall not receive a portion of the credits in the amount needed to cover the Town's cost to bring the line into conformance with the plans and specifications.
5. Upon completion of the line's construction and Town inspection approval, and payment by the Town, the Developer agrees to dedicate the line, and sufficient easements to repair and maintain the line, to the Town, thereby transferring ownership of the line and responsibility for its repair and maintenance to the Town.

IN WITNESS WHEREOF, the parties have hereto acting by and through their authorized representatives, have executed this instrument.

TOWN OF HEBRON

DEVELOPER

By: _____

By: _____

Office or title

Office or title

Date

Date

APPENDIX B

STANDARD DETAILS

APPENDIX B STANDARD DETAILS

<u>Title</u>	<u>Figure No.</u>
Adjusting Ring (Option 1).....	1
Adjusting Ring (Option 2).....	2
Air/Vacuum Release Valve & Vault Detail	3
Connection to Existing Manhole	4
Force Main Connection at Manhole	5
Inside Drop Manhole.....	6
Lift Station – Electrical Details	7
Lift Station – Pump Control Wiring Diagram	8
Outside Drop Manhole	9
Reducer Cap for Pre-cast Manhole Sections	10
Sanitary Sewer Connection Detail	11
New Service Connection to Existing Sanitary Sewer Main.....	12
Sanitary Sewer Repair	13
Service Lateral Connection.....	14
Sanitary Lateral For Deep Sewers (15' Deep and Over)	15
Sanitary Lateral For Shallow Sewers (Less than 15' Deep)	16
Standard Manhole Benches	17
Standard Sanitary Sewer Manhole	18
Gravity Plastic Trench.....	19
Buried Rigid Force Main Installation	20
Reinforced Concrete Pipe Trench	21
Type 1 Manhole Detail	22
Typical Force Main Connection to Manhole	23
Lift Station – Typical Section	24
Minimum Crossover & Separation Requirements.....	25
Ditch Crossing	26
Stream Crossing Details (Gravity Sewer)	27
Stream Crossing Plan & Profile (Force Main).....	28
Field Tile Repair	29
Standard Sanitary Sewer Manhole Frame & Cover.....	30
Sanitary Manhole Over Existing Sanitary Sewer Detail.....	31

Drawing: J:\Hebron\Projects\238721 Hebron Sewer Use Ordinance\CAD\DWG\Sheets\Adjusting Ring (Options 1).dwg | Layout: 8.5x11 Std | Plotted: 03/30/21 @ 04:13:07 | LastSavedBy: AllenS

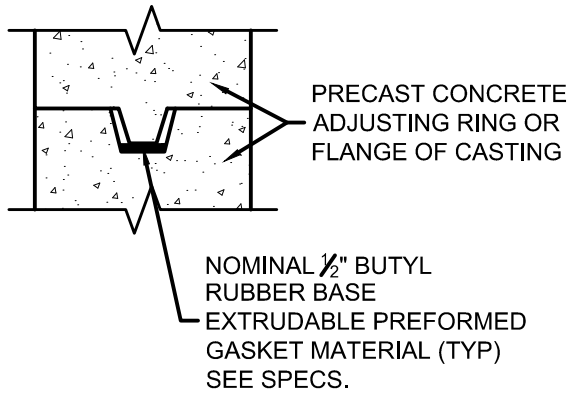
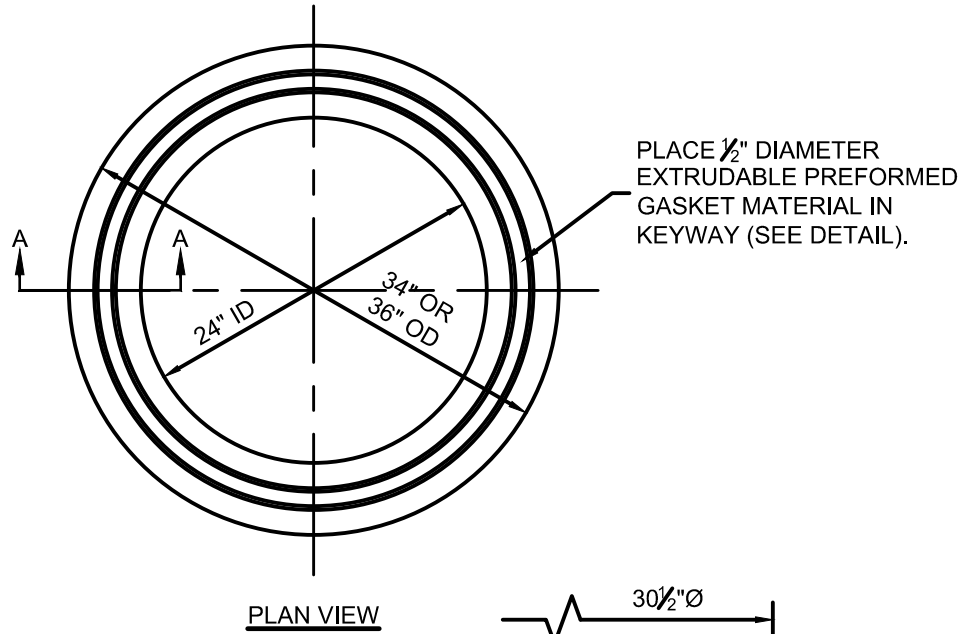

GASKET

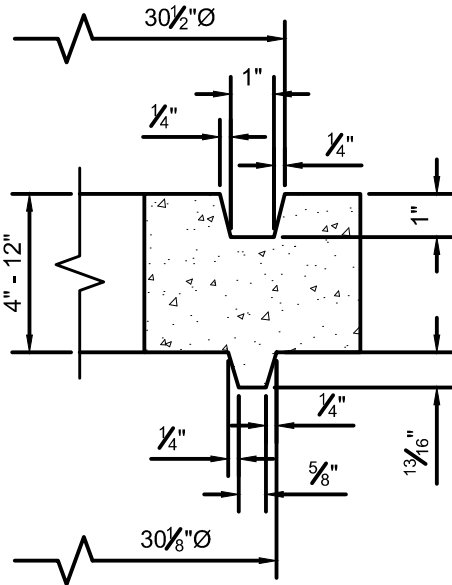

ADJUSTING RING (OPTION 1)

SCALE: NONE

Drawing: J:\Hebron\Projects\238721 Hebron Sewer Use Ordinance\CAD\DWG\Sheets\Adjusting Ring (Options 2).dwg | Layout: 8.5x11 Std | Plotted: 03/30/21 @ 04:01:20 | LastSavedBy: AllenS

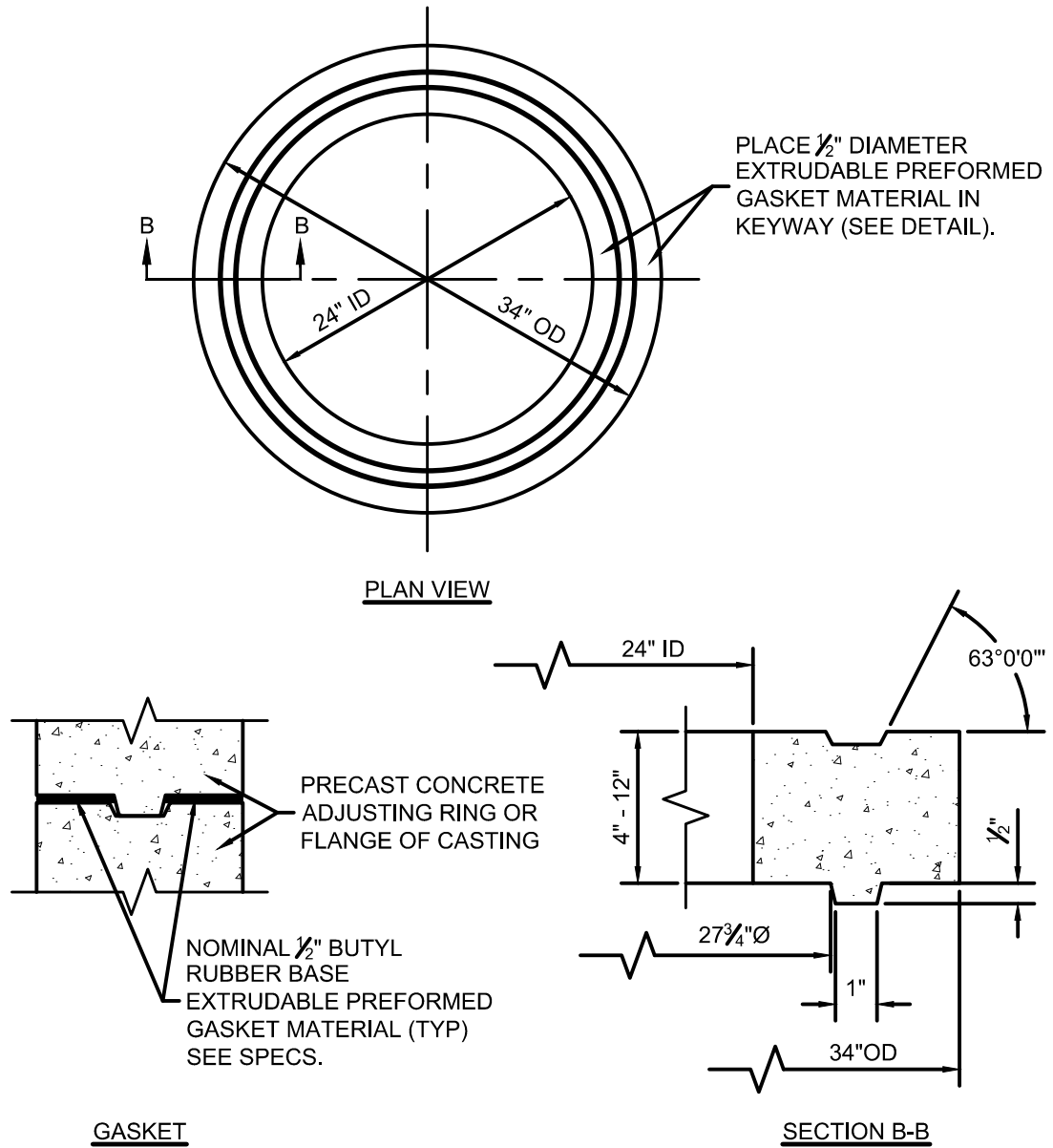

ADJUSTING RING (OPTION 2)
SCALE: NONE

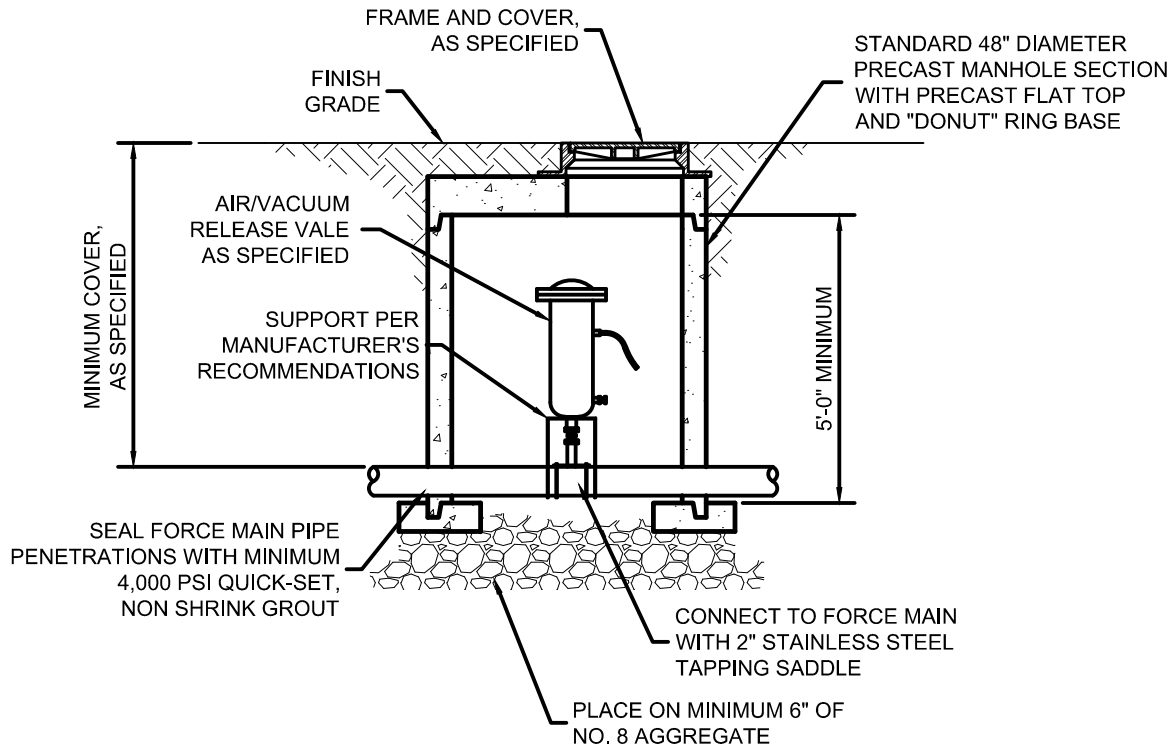

NOTES:

1. THE CONTRACTOR SHALL DETERMINE THE REQUIRED FORCE MAIN DEPTH AT THE STRUCTURE TO ENSURE THAT THE VALVE VAULT STRUCTURE DOES NOT EXTEND ABOVE FINISHED GRADE.
2. LOCATION OF AIR/VACUUM RELEASE STRUCTURES ARE APPROXIMATE. THE FINAL LOCATION TO BE DETERMINED IN THE FIELD BY THE CONTRACTOR AT THE HIGH ELEVATION POINT OF THE FORCE MAIN.

AIR/VACUUM RELEASE VALVE AND VAULT

SCALE: NONE

Drawing: J:\Hebron\Projects\238721 Hebron Sewer Use Ordinance\CAD\DWG\Sheets\Connection to Ex Manhole.dwg | Layout: 8.5x11 Std | Plotted: 03/30/21 @ 04:04:18 | LastSavedBy: JasonW

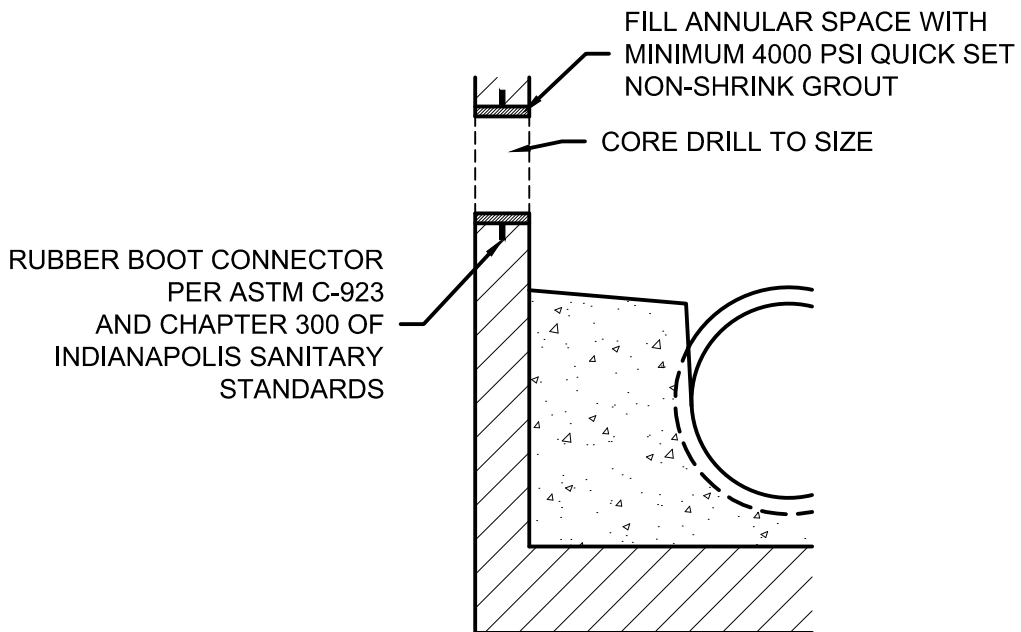

CONNECTION TO EXISTING MANHOLE

SCALE: NONE

Drawing: J:\Hebron\Projects\238721 Hebron Sewer Use Ordinance\CAD\DWG\Sheets\FM Connect At MH.dwg | Layout: 8.5x11 Std | Plotted: 03/30/21 @ 04:08:03 | LastSavedBy: DonT

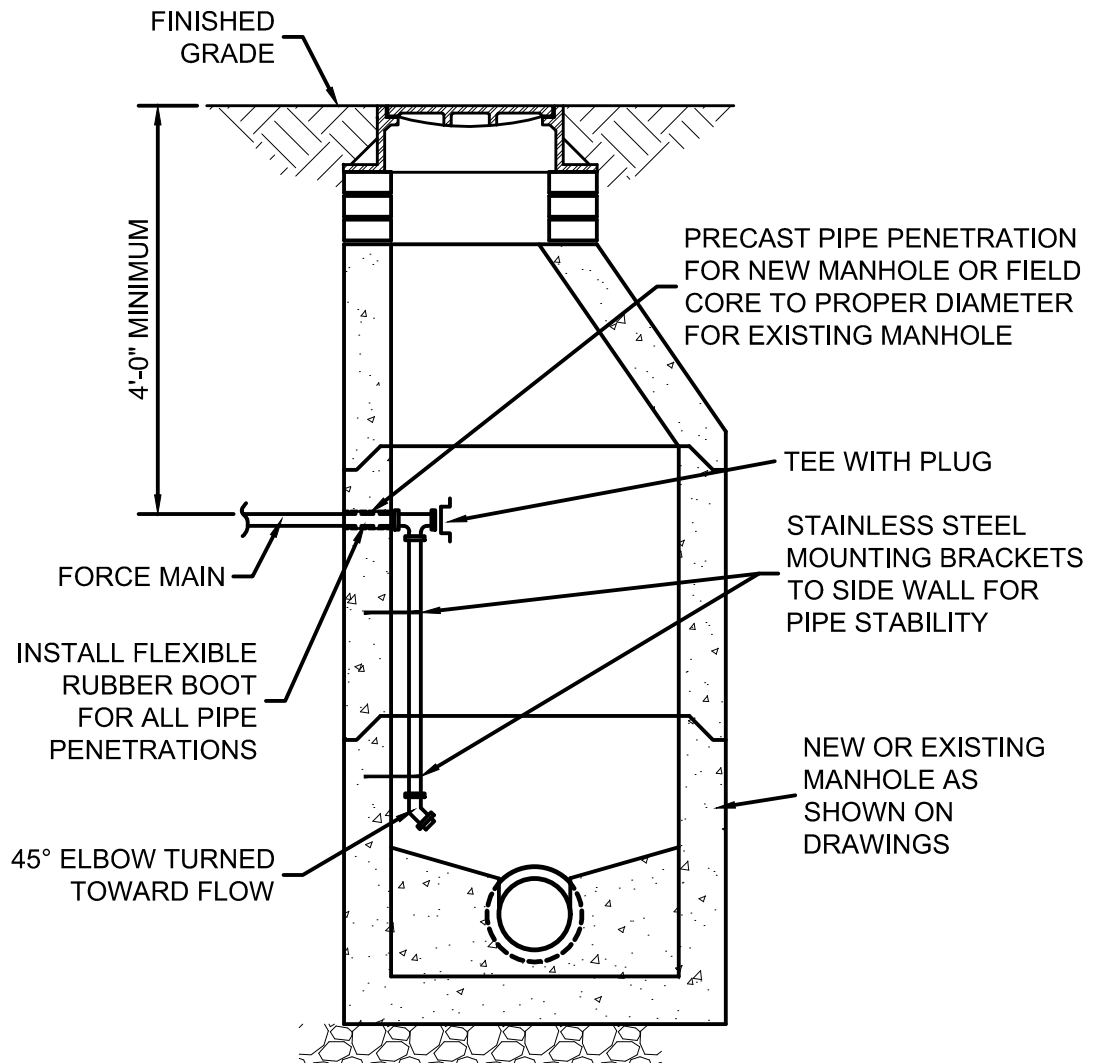

NOTES:

1. NEW MANHOLE CONSTRUCTION AND ACCESSORIES SAME AS SHOWN FOR STANDARD SANITARY SEWER MANHOLE.

FORCE MAIN CONNECTION AT MANHOLE

SCALE: NONE

Drawing: J:\Hebron\Projects\238721 Hebron Sewer Use Ordinance\CAD\DWG\Sheets\Inside Drop MH.dwg | Layout: 8.5x11 Std | Plotted: 03/30/21 @ 04:09:41 | LastSavedBy: AllenS

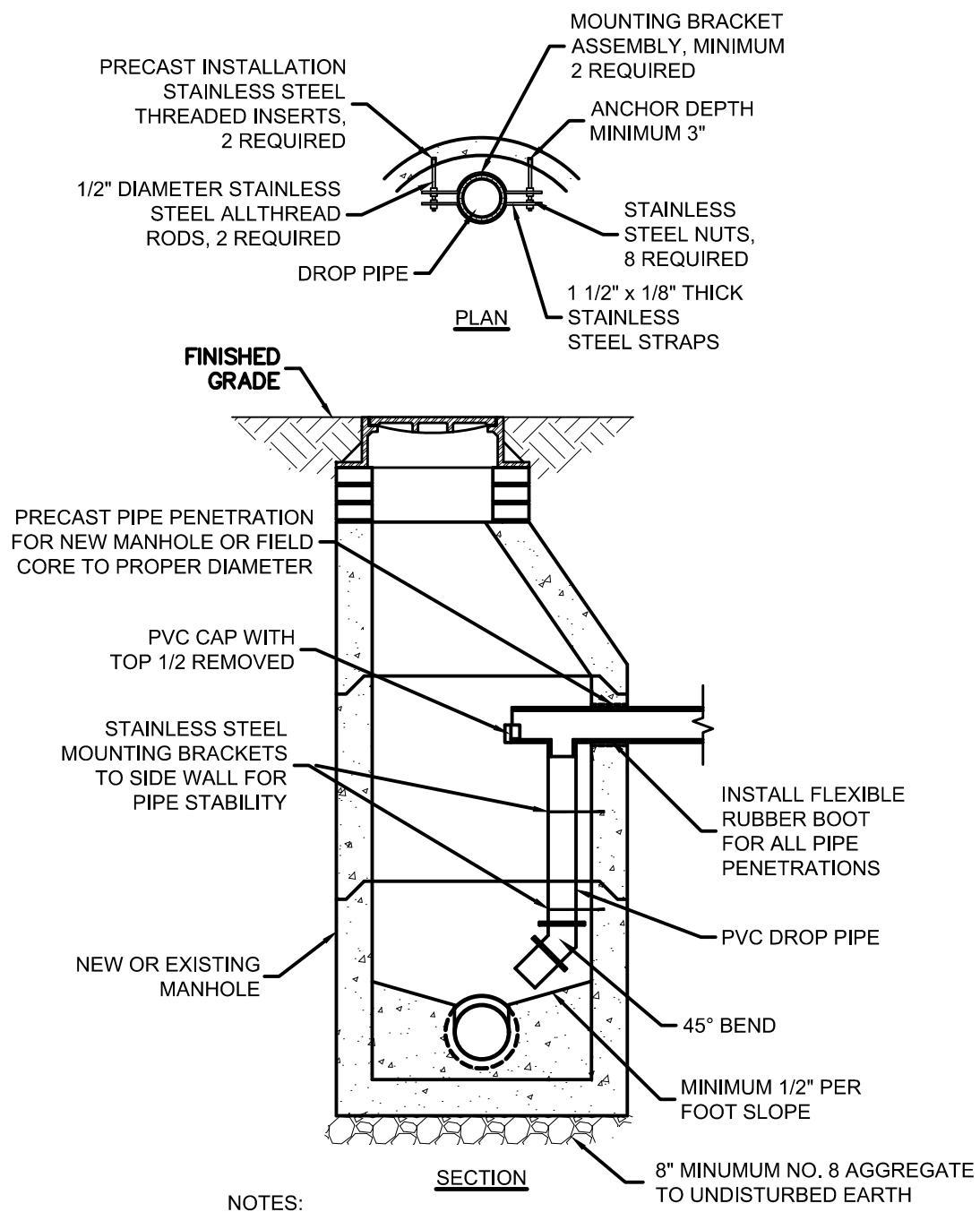

NOTES:
 1. NEW MANHOLE CONSTRUCTION AND ACCESSORIES SAME AS SHOWN FOR STANDARD SANITARY SEWER MANHOLE.

INSIDE DROP MANHOLE
 SCALE: NONE

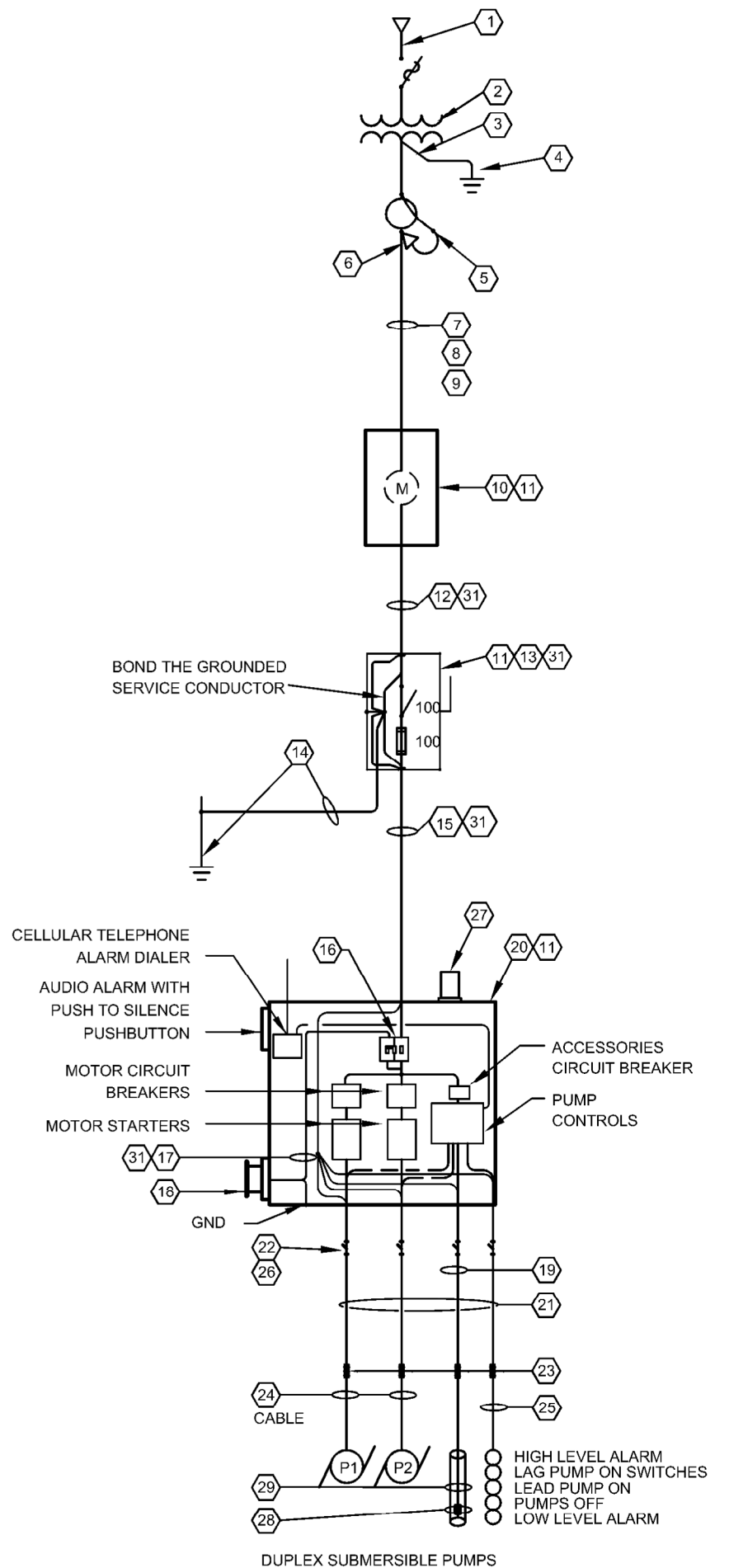

FIGURE 6
 Hebron Public Works Department
 Sanitary Sewer Standard Details

April 2021

NOTES

- ① AERIAL MEDIUM VOLTAGE CONDUCTORS.
- ② TRANSFORMER BANK ON ELEC. UTILITY CO. POLE.
- ③ UTILITY CO WOOD POLE.
- ④ GROUNDING AT ELECTRIC UTILITY POLE.
- ⑤ CONNECTION TO RISER CONDUCTORS.
- ⑥ WEATHERHEAD AND CONDUCTOR PIGTAILS.
- ⑦ 1 - 4" SCHEDULE 40 PVC CONDUIT RISER SPACED 9" AWAY FROM POLE.
- ⑧ SERVICE CONDUCTORS IN 1 - 4" SCHEDULE 40 PVC CONDUIT.
- ⑨ USE SCHEDULE 40 PVC CONDUIT ABOVE AND BELOW GROUND FOR ELECTRICAL SERVICE. USE GRS ELLS AND STUBS AT THE METER BASE.
- ⑩ METER AND BASE.
- ⑪ BOND BUSHINGS AND BONDING OF CONDUITS AND ENCLOSURES.
- ⑫ 3-#1, 1-#6 GROUND, 1 1/2" GRS C. MINIMUM SERVICE SIZE. CONFIRM SERVICE SIZE IF MOTORS ARE LARGER THAN 7.5HP, 230V, 3 PHASE.
- ⑬ GROUNDED FUSED MAIN DISCONNECT SWITCH, WITH NEMA STAINLESS STEEL ENCLOSURE.
- ⑭ 5/8" X 8'-0" COPPER-CLAD GROUND ROD AND #6 GROUND, 3/4" C.
- ⑮ 3-#1, 1-#6 GROUND, 1 1/2" GRS C MINIMUM SERVICE SIZE. CONFIRM SERVICE SIZE IF MOTORS ARE LARGER THAN 7.5HP, 230V, 3 PHASE.
- ⑯ GENERATOR RECEPTACLE AND PUMP PANEL CIRCUIT BREAKER WITH MECHANICAL INTERLOCK (WALKING BEAM).
- ⑰ 3-#1, 1-#6 GROUND, MINIMUM SIZE. CONFIRM SIZE IF MOTORS ARE LARGER THAN 7.5HP, 230V, 3 PHASE.
- ⑱ PIN AND SLEEVE NEMA 4X RECEPTACLE FOR CONNECTION OF PORTABLE GENERATOR. CONFIRM CONFIGURATION WITH OWNER.
- ⑲ LEVEL SENSOR CABLE.
- ⑳ PUMP MOTOR CONTROL PANEL.
- ㉑ GALVANIZED RIGID STEEL CONDUITS, PUMP CABLES, FLOAT CABLES, AND LEVEL SENSOR CABLE.
- ㉒ GALVANIZED RIGID STEEL CONDUITS AND CONDUIT SEALS; APPROPRIATE FOR CLASS 1, DIVISION 1, GROUP D HAZARDOUS ENVIRONMENT.
- ㉓ STRAIN RELIEF CABLE GRIP AND HOOK FOR SUPPORT OF POWER AND CONTROL CABLES, ACCESSIBLE FROM WET WELL HATCH.
- ㉔ CABLES WITH PUMP POWER AND SENSOR CONDUCTORS.
- ㉕ WEIGHTED CABLE SET AND FLOAT SWITCHES.
- ㉖ HAZARDOUS ATMOSPHERE; ALL CONDUITS ENTERING WET WELL SHALL HAVE APPROVED CONDUIT SEALS INSTALLED.
- ㉗ ALARM BEACON.
- ㉘ SUBMERSIBLE LEVEL TRANSMITTER TO BE LOCATED BELOW THE LOWEST FLOAT SWITCH.
- ㉙ PVC STILLING TUBE MOUNTED TO THE SIDE OF THE WELL AND SUPPORTED EVERY 5' WITH 316 STAINLESS STEEL HARDWARE.
- ㉚ BACKUP FLOATS SHALL BE PLACED ABOVE NORMAL CONTROL RANGE OF THE CONTROLLER AND SUBMERSIBLE LEVEL TRANSMITTER AT EACH SET POINT.
- ㉛ 100A MINIMUM SERVICE SIZE IS ONLY ALLOWED FOR MOTOR SIZES UP TP 7.5HP @ 230V 3 PHASE.



240V, 3PH SERVICE, LIFT-STATION ONE-LINE DIAGRAM

SCALE: NONE

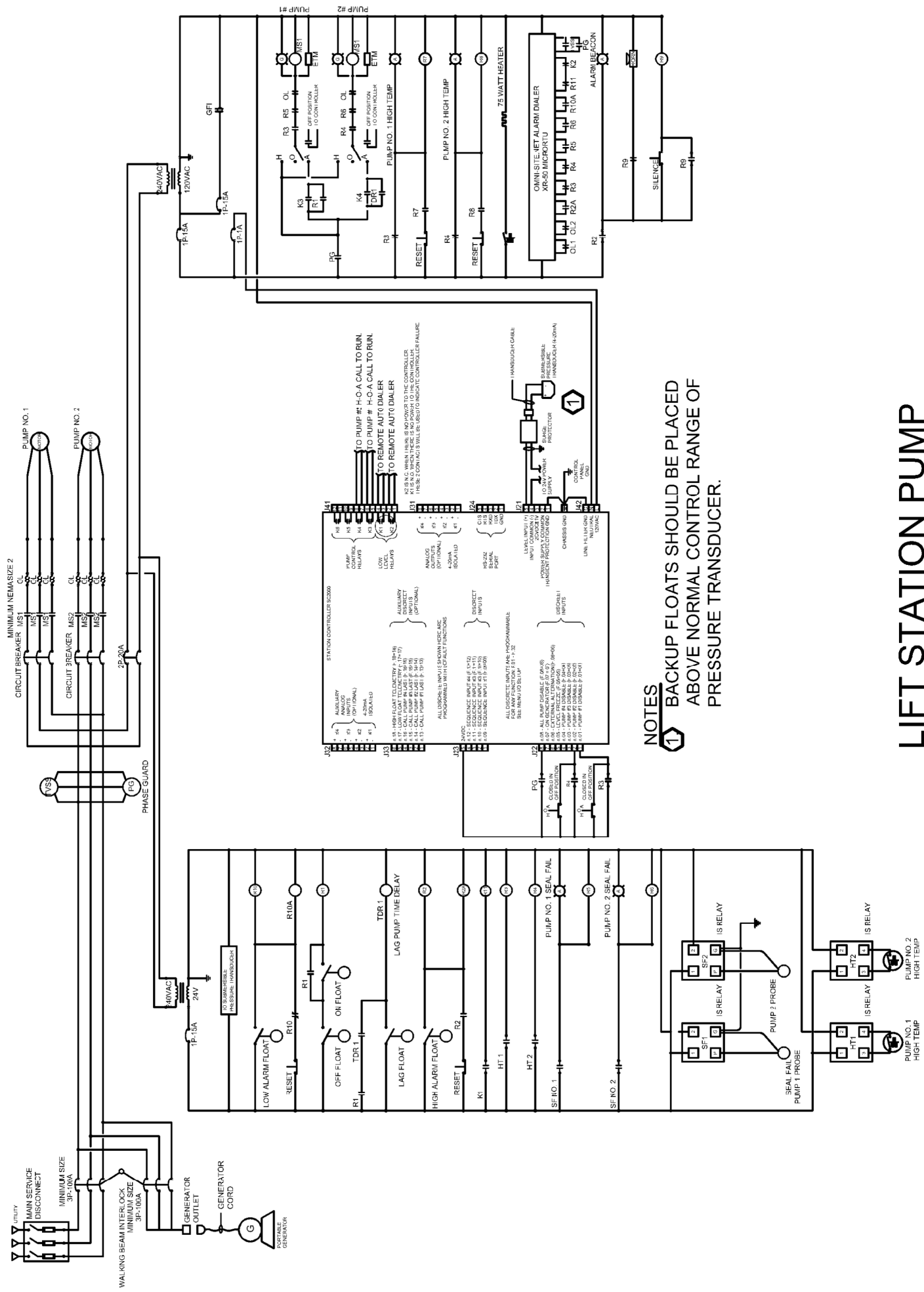

NOTES
 1) BACKUP FLOATS SHOULD BE PLACED ABOVE NORMAL CONTROL RANGE OF PRESSURE TRANSDUCER.

LIFT STATION PUMP CONTROL WIRING DIAGRAM

SCALE: NONE

Drawing: J:\Hebron\Projects\238721 Hebron Sewer Use Ordinance\CAD\DWG\Sheets\Outside Drop MH.dwg | Layout: 8.5x11 Std | Plotted: 03/30/21 @ 04:11:32 | LastSavedBy: Allens

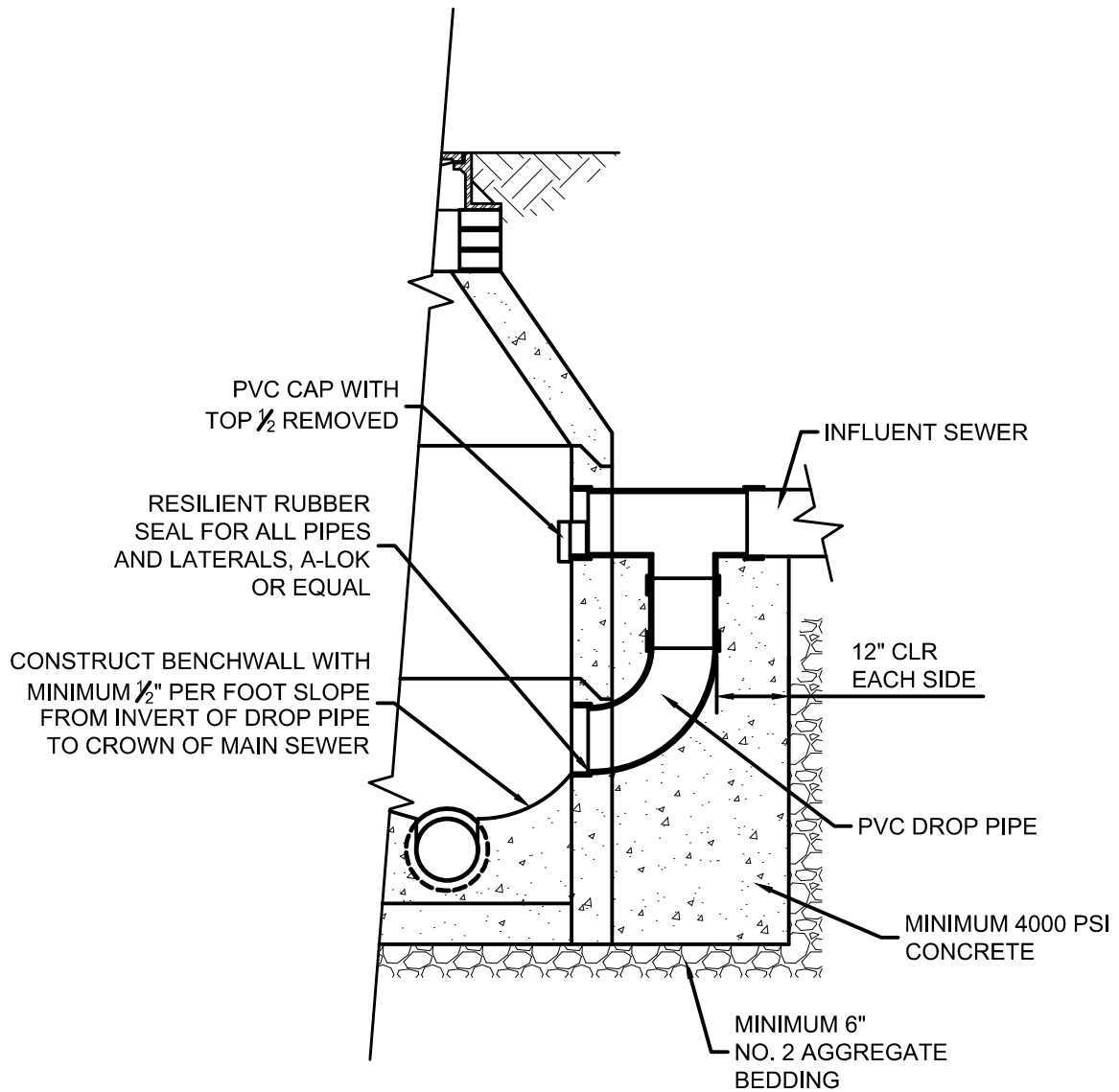

NOTES:

1. MANHOLE CONSTRUCTION AND ACCESSORIES SAME AS SHOWN FOR STANDARD SANITARY SEWER MANHOLE.

OUTSIDE DROP MANHOLE

SCALE: NONE

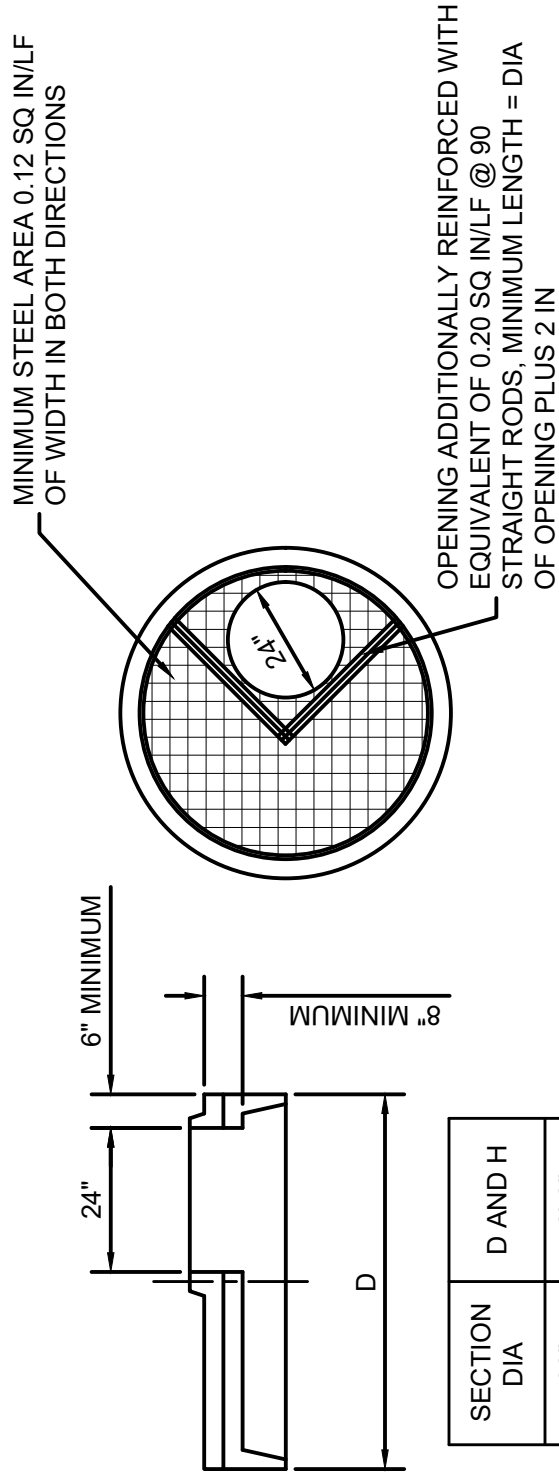

REDUCER CAP FOR PRE-CAST MANHOLE SECTIONS

SCALE: NONE

FIGURE 10
 Hebron Public Works Department
 Sanitary Sewer Standard Details

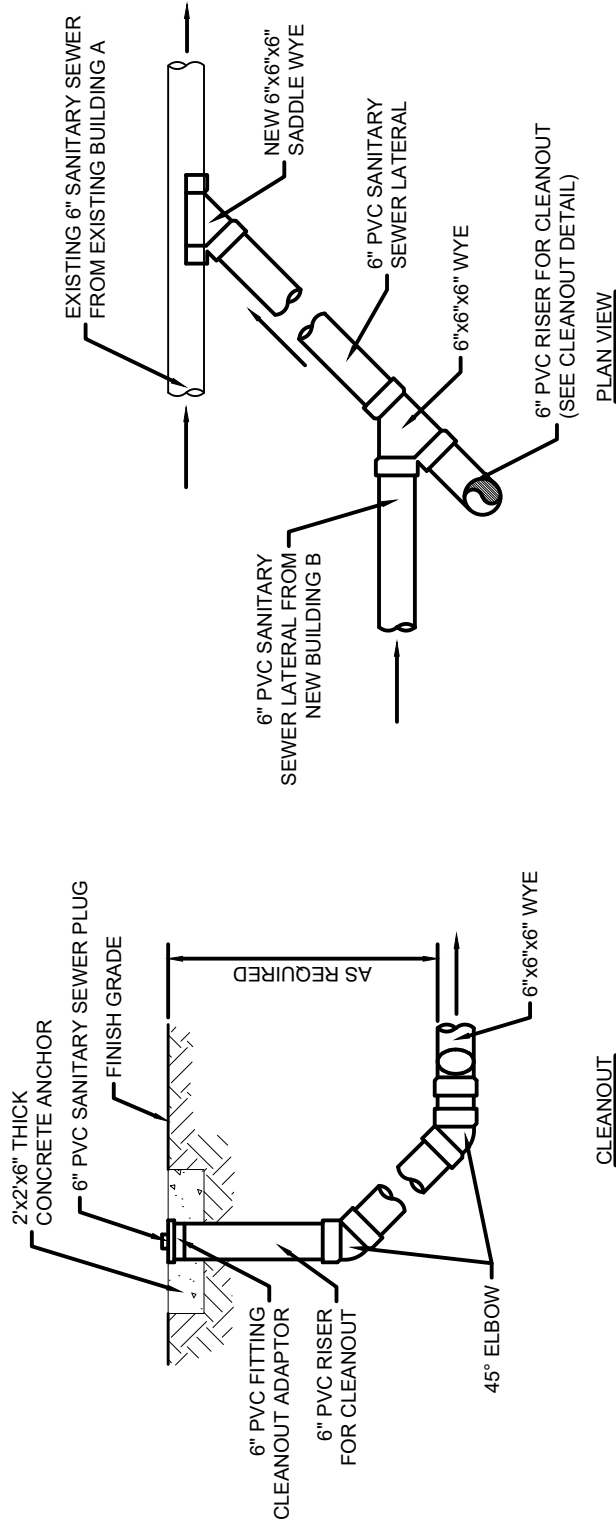

CLEANOUT

PLAN VIEW

SANITARY SEWER CONNECTION

SCALE: NONE

FIGURE 11
Hebron Public Works Department
Sanitary Sewer Standard Details

Drawing: J:\Hebron\Projects\238721 Hebron Sewer Use Ordinance\CAD\DWG\Sheets\Sanitary Sewer Connection.dwg | Layout: 8.5x11 Std | Plotted: 04/20/21 @ 11:12:15 | LastSavedBy: AllenS

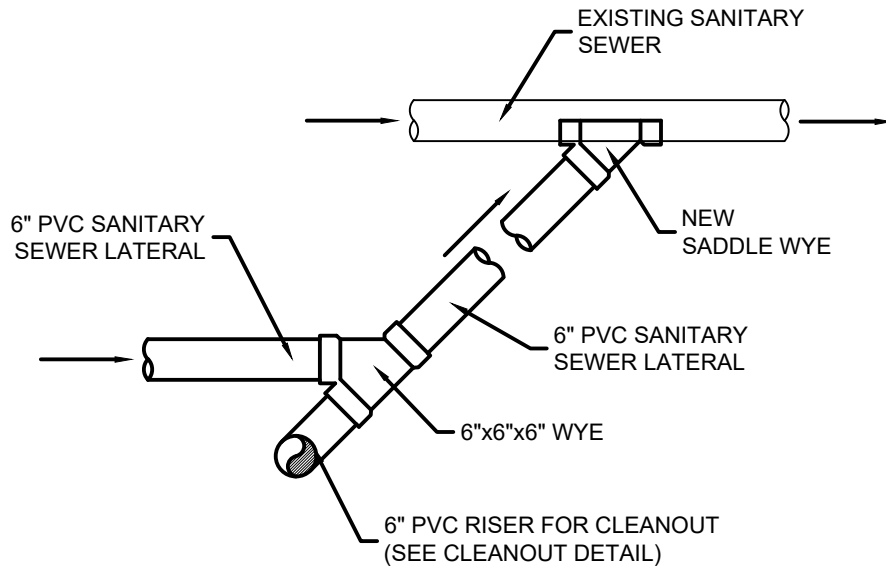

PLAN VIEW

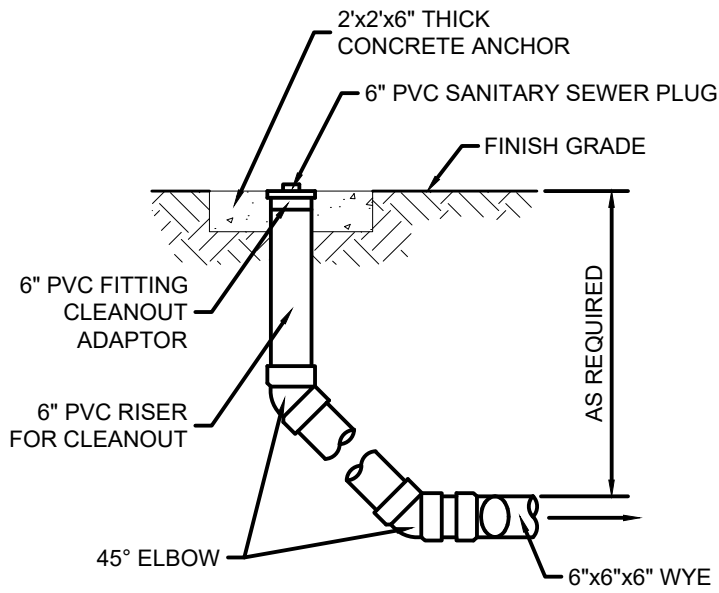

CLEANOUT

NEW SERVICE CONNECTION TO EXISTING SANITARY SEWER

SCALE: NONE



FIGURE 12
Hebron Public Works Department
Sanitary Sewer Standard Details

April 2021

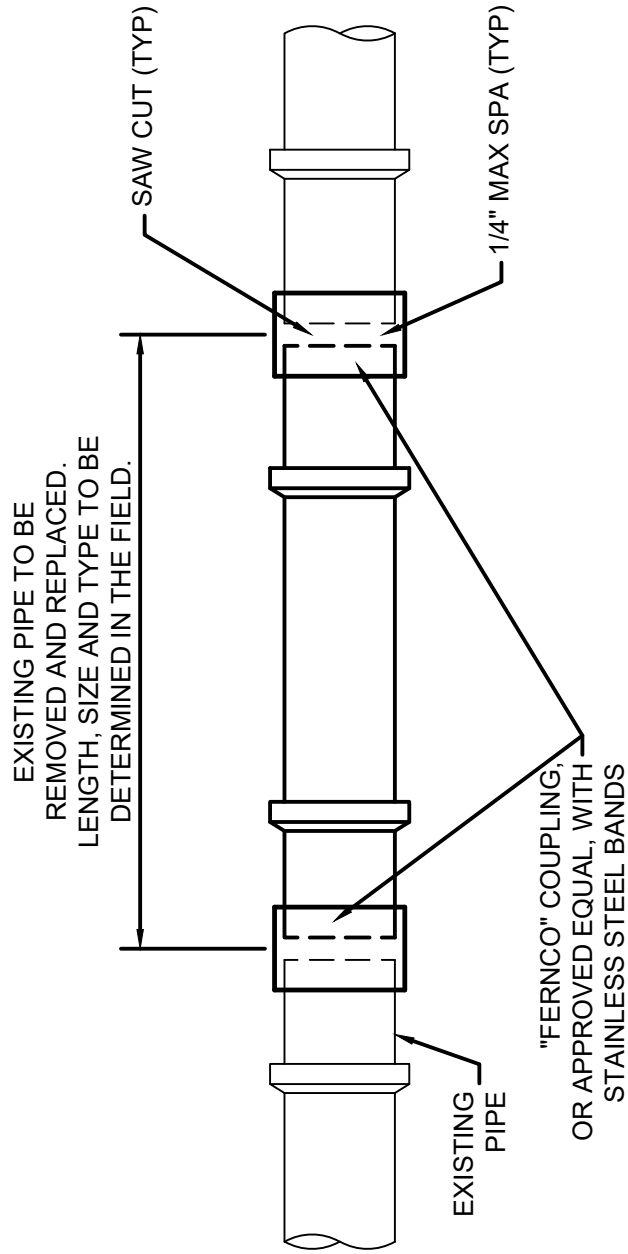

SANITARY SEWER REPAIR

SCALE: NONE

Drawing: J:\Hebron\Projects\238721 Hebron Sewer Use Ordinance\CAD\DWG\Sheets\Serve Lat Connect.dwg | Layout: 8.5x11 Std | Plotted: 04/20/21 @ 11:06:13 | LastSavedBy: AllenS

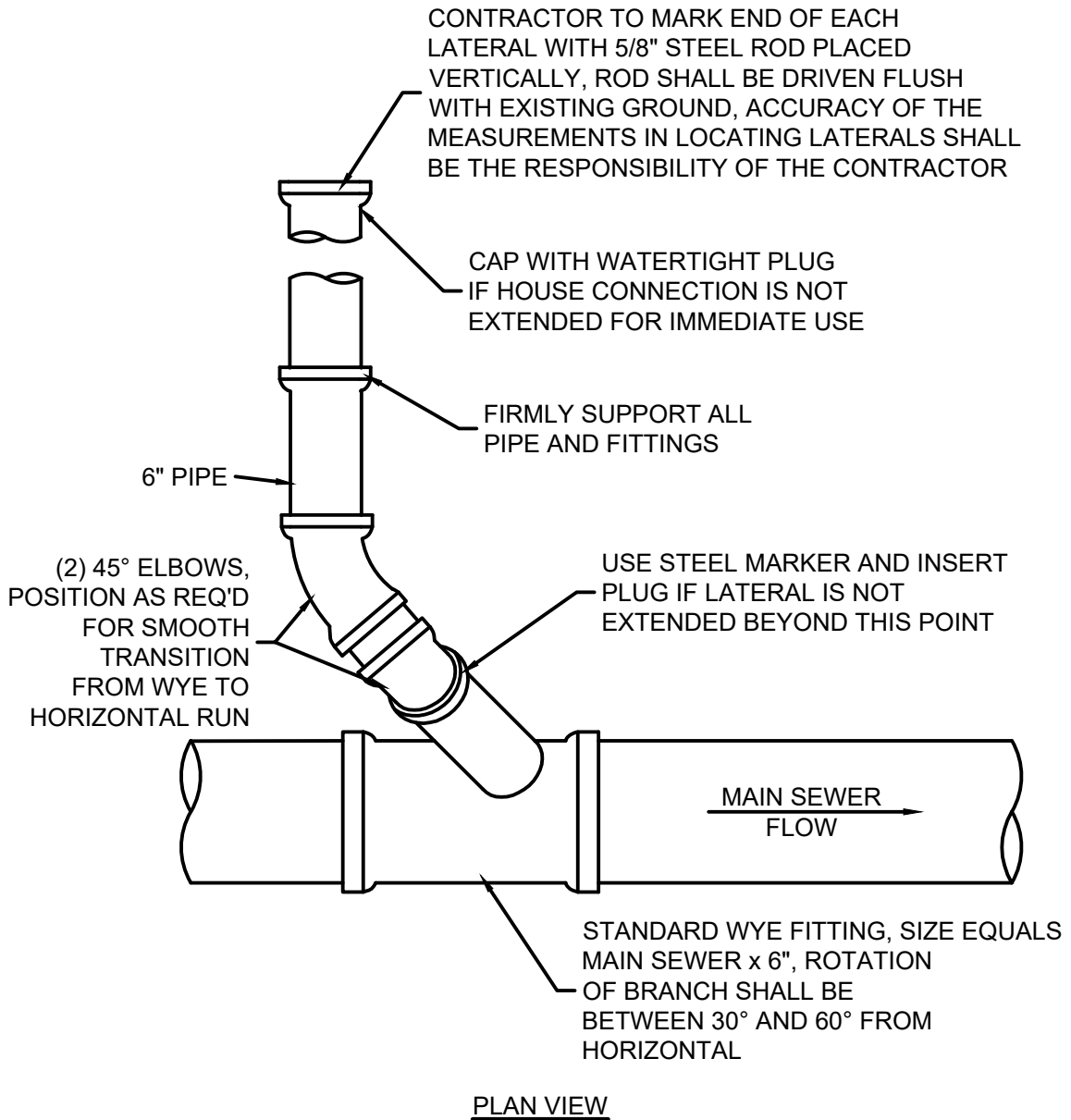

SERVICE LATERAL CONNECTION

SCALE: NONE

Drawing: J:\Hebron\Projects\238721 Hebron Sewer Use Ordinance\CAD\DWG\Sheets\Service Connect-Deep.dwg | Layout: 8.5x11 Std | Plotted: 04/20/21 @ 11:03:11 | LastSavedBy: AllenS

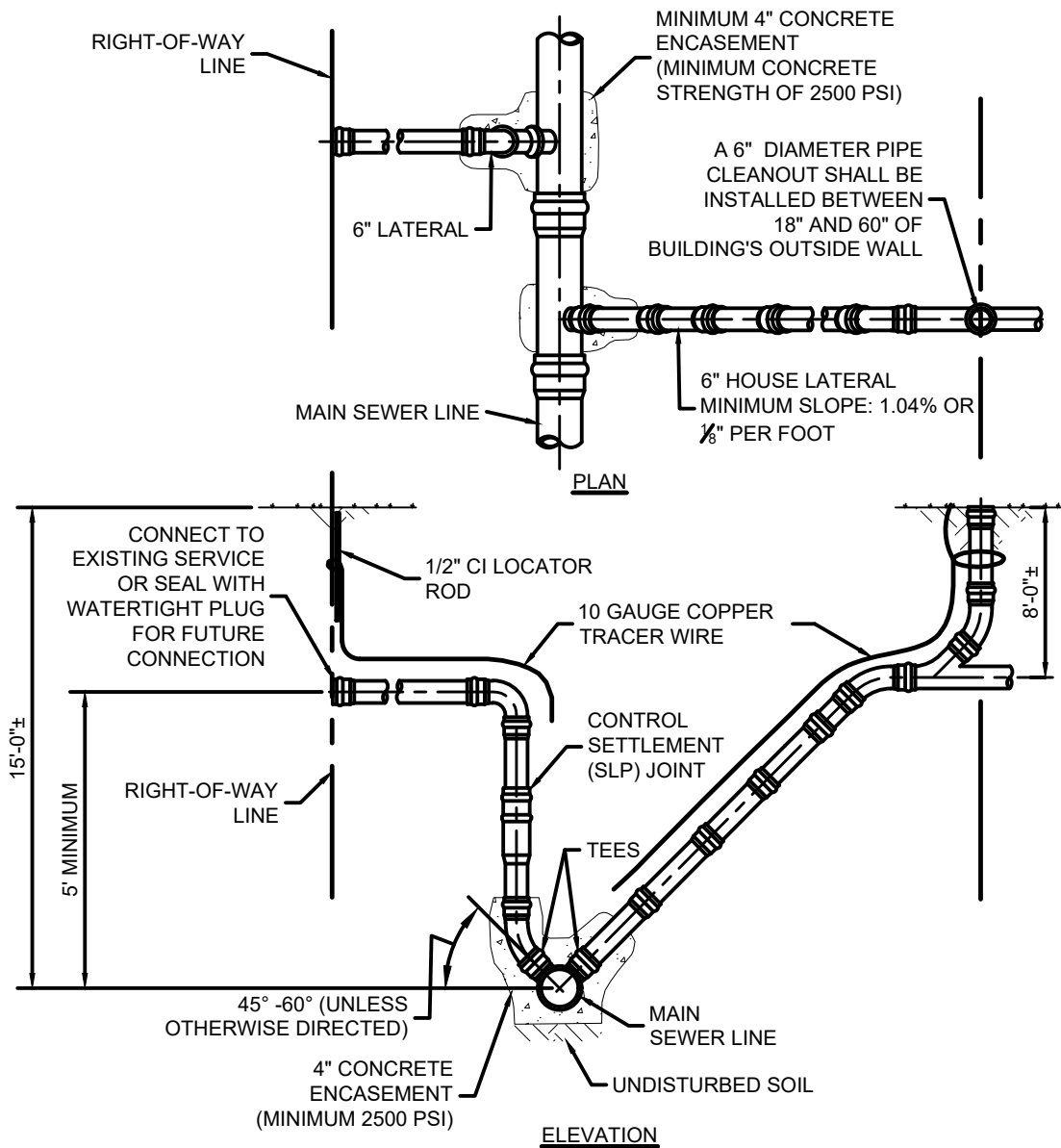

NOTES:

1. SANITARY LATERALS SHALL BE INSTALLED WHERE INDICATED. THEY SHALL BE EXTENDED TO RIGHT-OF-WAY LINES OR TO DISTANCES AS SHOWN ON THE DRAWINGS, AND SHALL BE 6" PIPE UNLESS OTHERWISE SHOWN.
2. THE DEPTH OF THE LATERAL AT THE PROPERTY LINE SHALL BE APPROXIMATELY 8'-0" UNLESS SEWER DEPTH IS LESS, A MINIMUM SLOPE OF 1/8" PER 1'-0" SHALL BE USED.

SANITARY LATERAL FOR DEEP SEWERS (15' DEEP AND OVER)

SCALE: NONE



FIGURE 15
Hebron Public Works Department
Sanitary Sewer Standard Details

April 2021

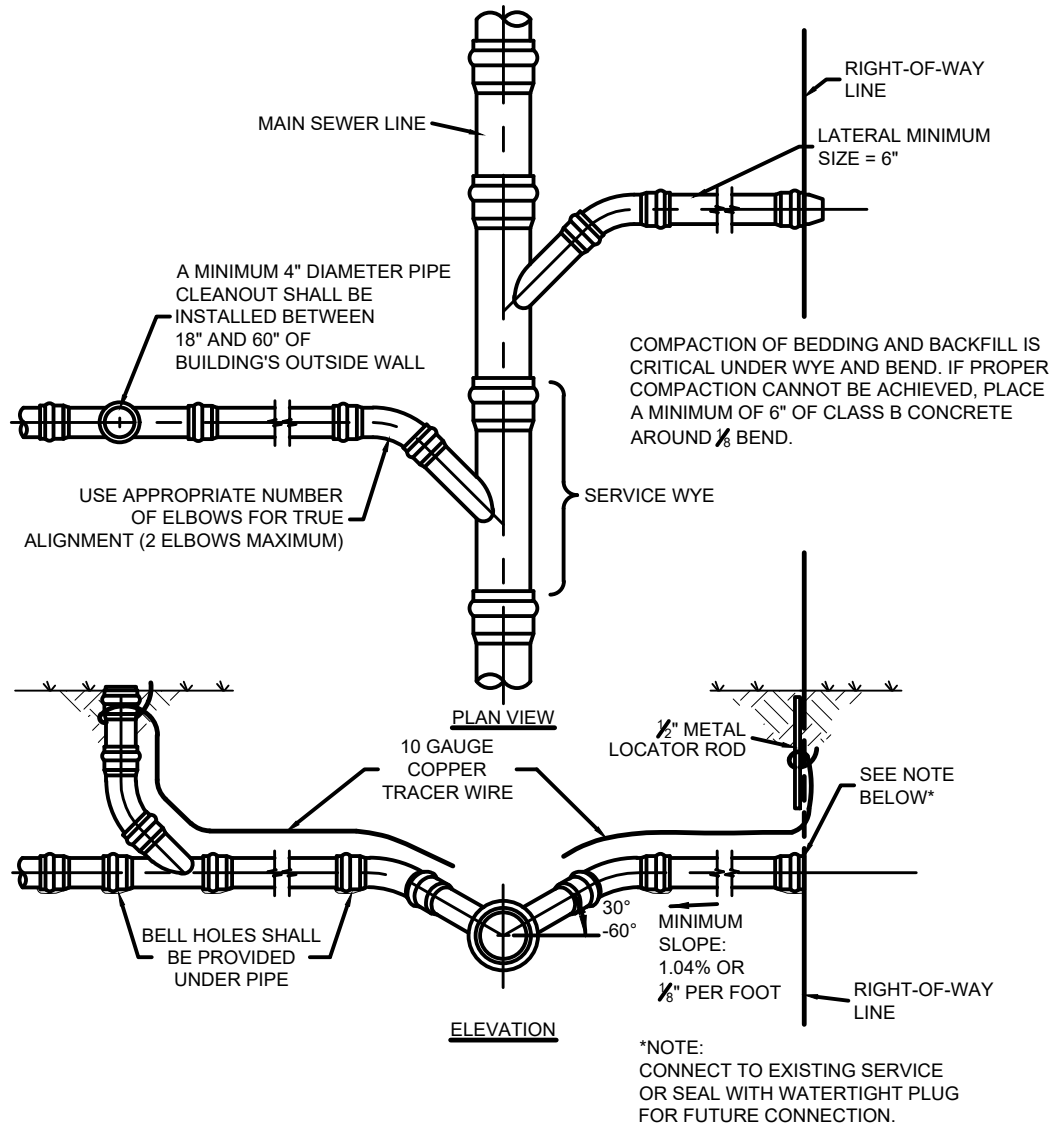

SANITARY LATERAL FOR SHALLOW SEWERS (LESS THAN 15' DEEP)

SCALE: NONE

Drawing: J:\Hebron\Projects\238721 Hebron Sewer Use Ordinance\CAD\DWG\Sheets\STD MH BENCH.DWG | Layout: 8.5x11 Std | Plotted: 04/20/21 @ 10:58:06 | LastSavedBy: AllenS

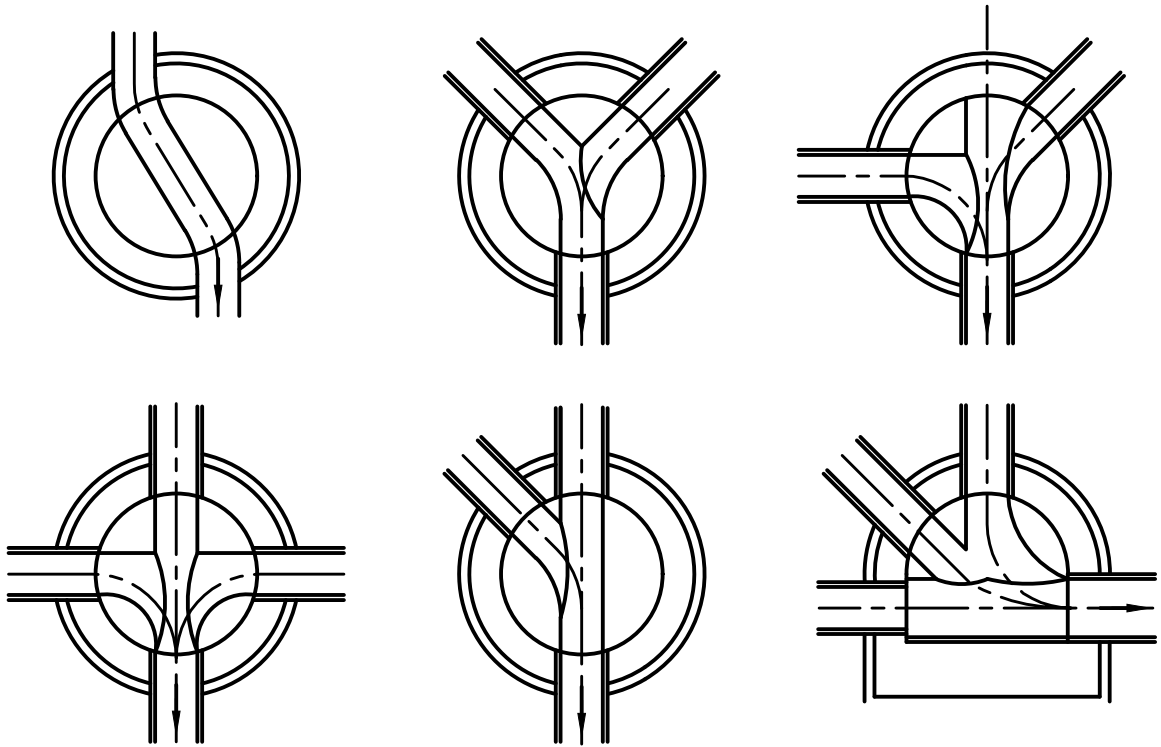

NOTES:
1. SANITARY SEWER BENCH SLOPE = $\frac{1}{2}$ " PER FOOT

STANDARD MANHOLE BENCHES

SCALE: NONE



FIGURE 17
Hebron Public Works Department
Sanitary Sewer Standard Details

April 2021

Drawing: J:\Hebron\Projects\238721 Hebron Sewer Use Ordinance\CAD\DWG\Sheets\Std Sanitary MH.dwg | Layout: 8.5x11 Std | Plotted: 04/20/21 @ 10:55:17 | LastSavedBy: AllenS

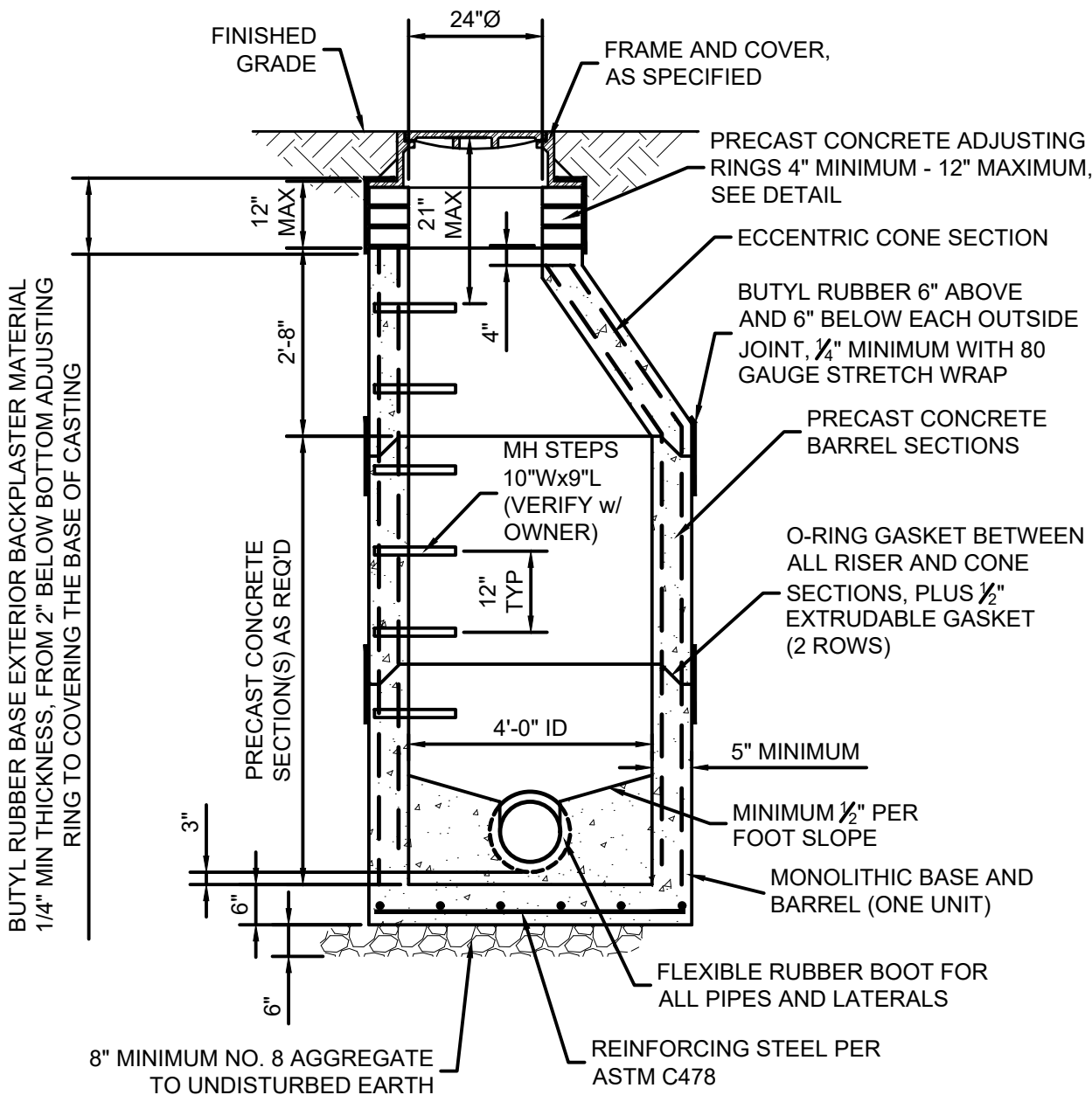

STANDARD SANITARY SEWER MANHOLE
SCALE: NONE



FIGURE 18
Hebron Public Works Department
Sanitary Sewer Standard Details

Drawing: J:\Hebron\Projects\238721 Hebron Sewer Use Ordinance\CAD\DWG\Sheets\TB-02220-Plastic-Gravity.dwg | Layout: 8.5x11 Std | Plotted: 04/20/21 @ 10:52:47 | LastSavedBy: Allens

PIPE SIZE	8" TO 16"	18" TO 30"	33" AND OVER
BEDDING BELOW THE PIPE BARREL	4"	OD / 4	8"

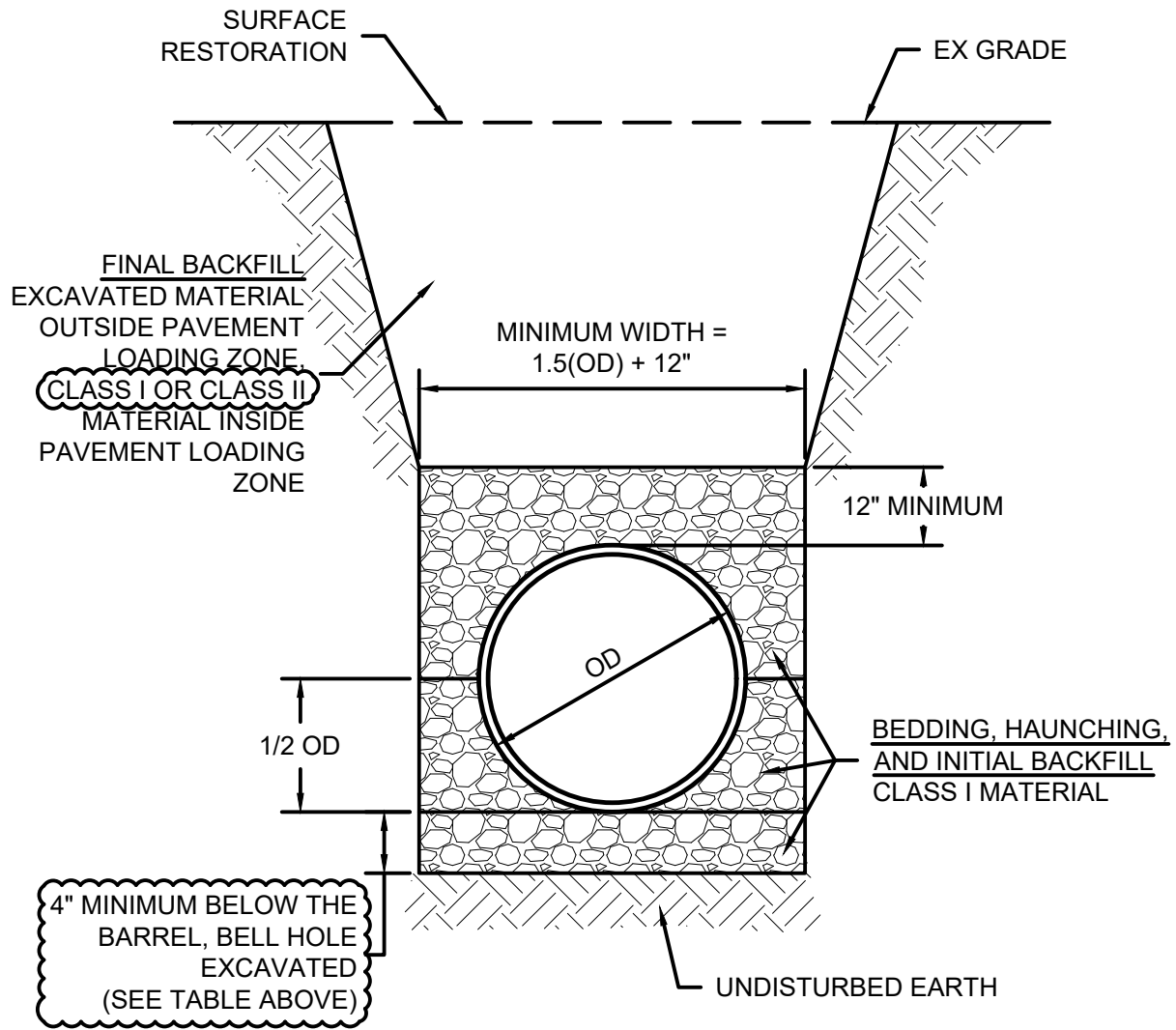

FLEXIBLE (HDPE, PP, PVC) PIPE TRENCH

SCALE: NONE



FIGURE 19
Hebron Public Works Department
Sanitary Sewer Standard Details

April 2021

Drawing: J:\Hebron\Projects\238721 Hebron Sewer Use Ordinance\CAD\DWG\Sheets\Fig 20 SI-02220-YardPiping-ProcessPipeInstallation.dwg | Layout: STD | Plotted: 04/27/21 @ 11:26:03 | LastSavedBy: AllenS

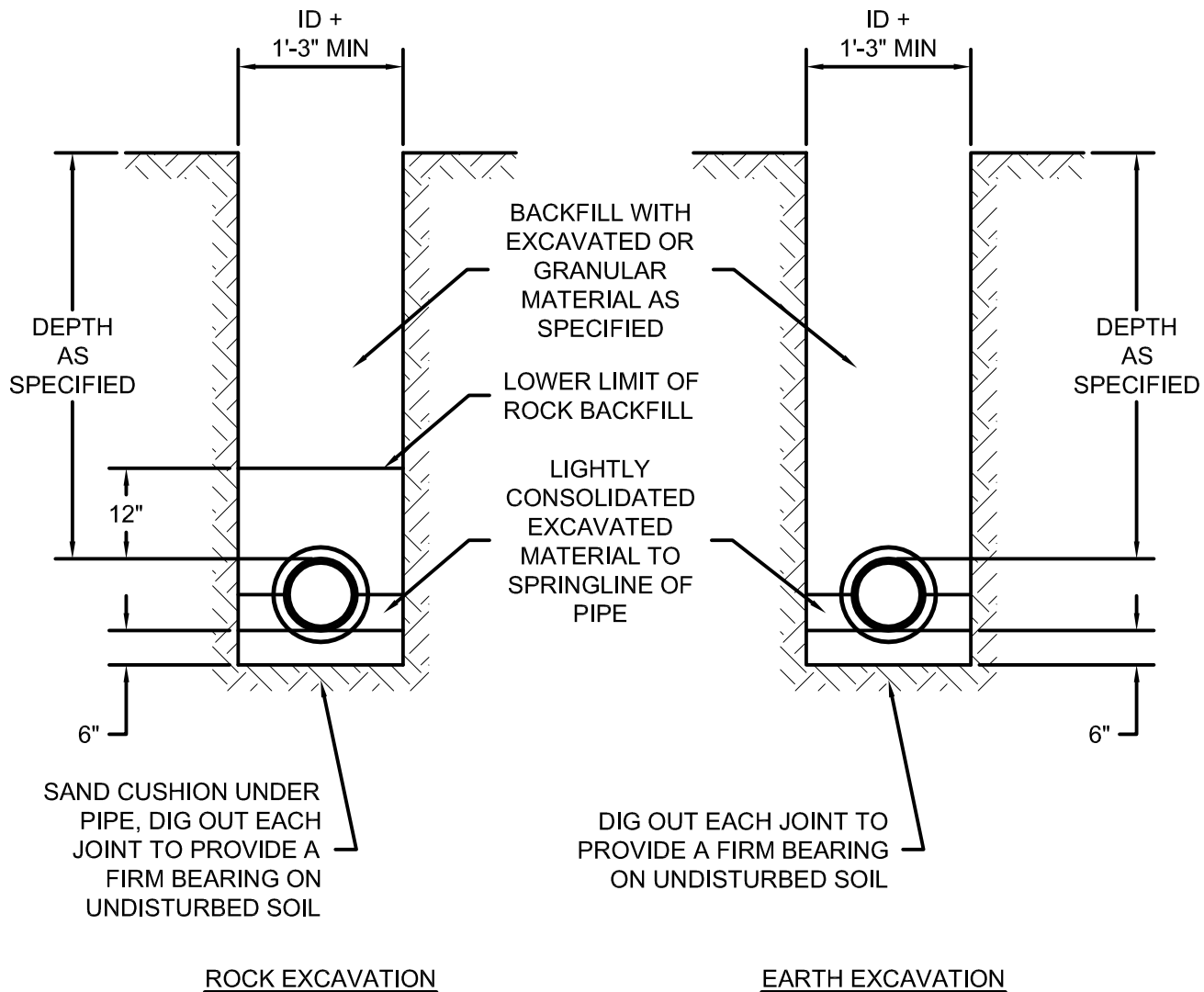

BURIED RIGID FORCE MAIN PIPE INSTALLATION

SCALE: NONE



More than a Project™

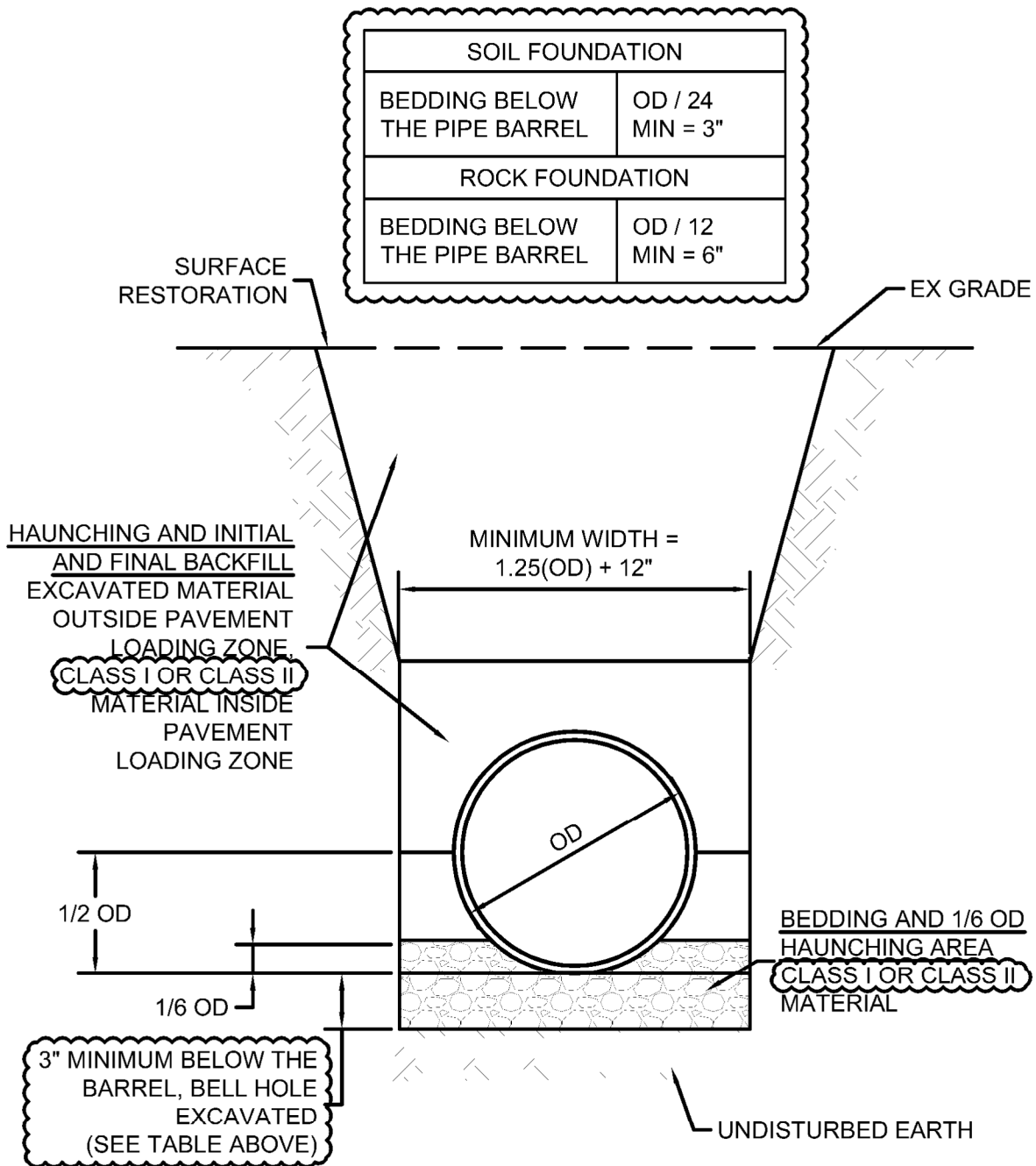

FIGURE 20

Hebron Public Works Department
Sanitary Sewer Standard Details

April 2021

Drawing: J:\Hebron\Projects\238721 Hebron Sewer Use Ordinance\CAD\DWG\Sheets\TB-02220-RCP.dwg | Layout: 8.5x11 Std | Plotted: 04/28/21 @ 09:44:30 | LastSavedBy: AllenS



REINFORCED CONCRETE PIPE (RCP) TRENCH

SCALE: NONE



More than a Project™



FIGURE 21

Hebron Public Works Department
Sanitary Sewer Standard Details

April 2021

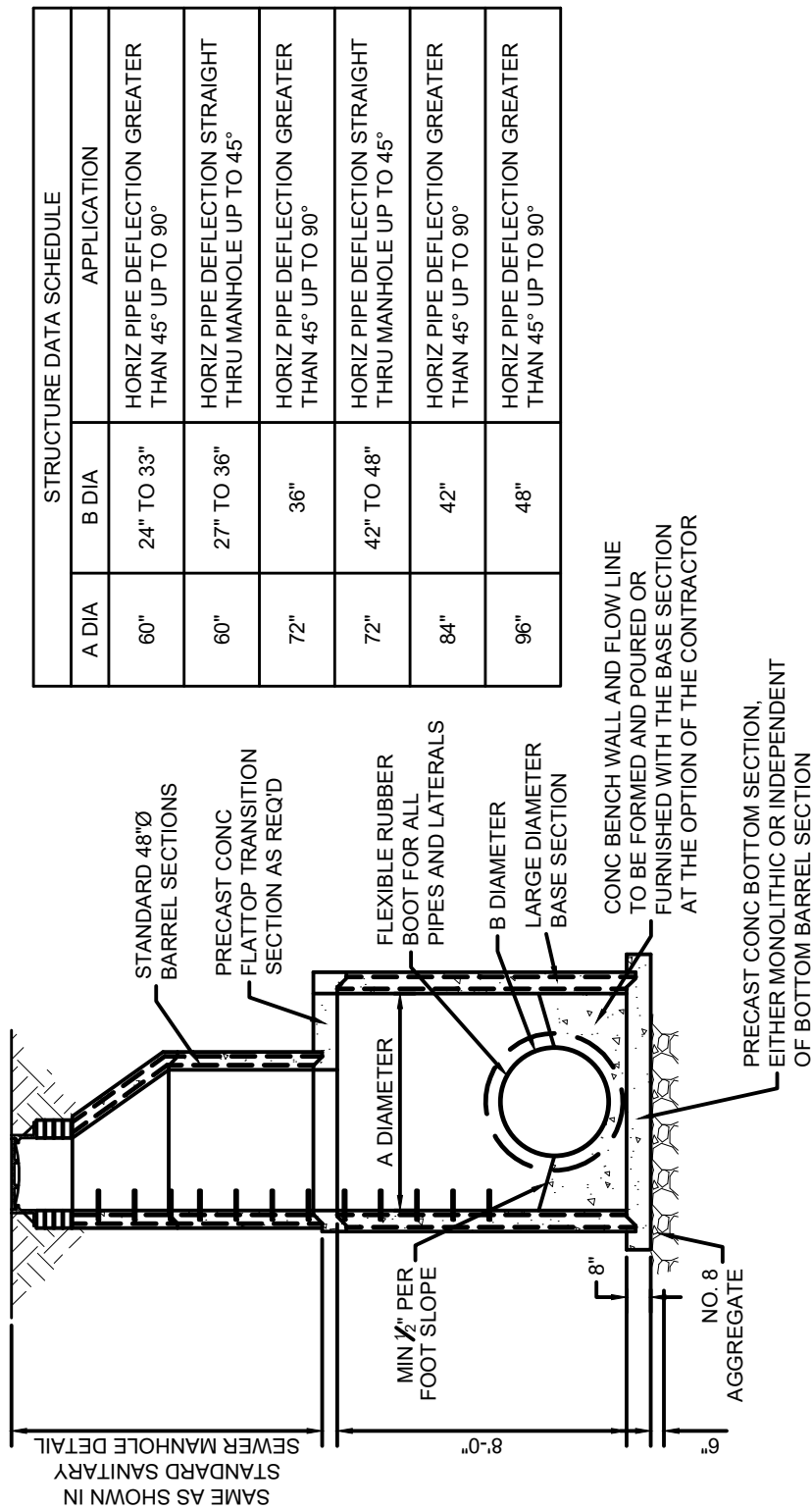

TYPE 1 MANHOLE
SCALE: NONE

Drawing: J:\Hebron\Projects\238721 Hebron Sewer Use Ordinance\CAD\DWG\Sheets\TYPICAL FM CONNECT AT MH.DWG | Layout: 8.5x11 Std | Plotted: 04/20/21 @ 10:41:46 | LastSavedBy: AllenS

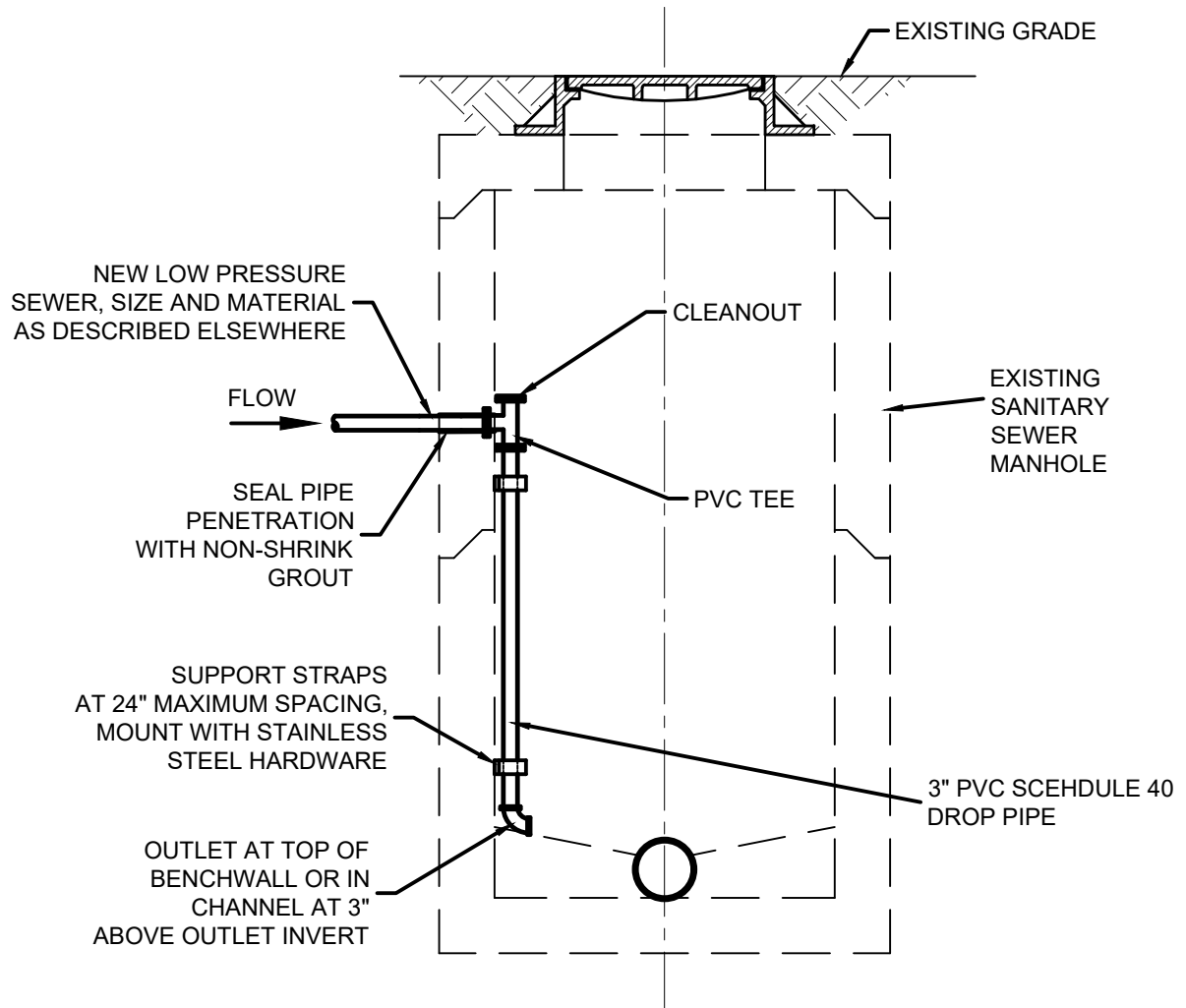

TYPICAL FORCE MAIN CONNECTION TO MANHOLE

SCALE: NONE



More than a Project™

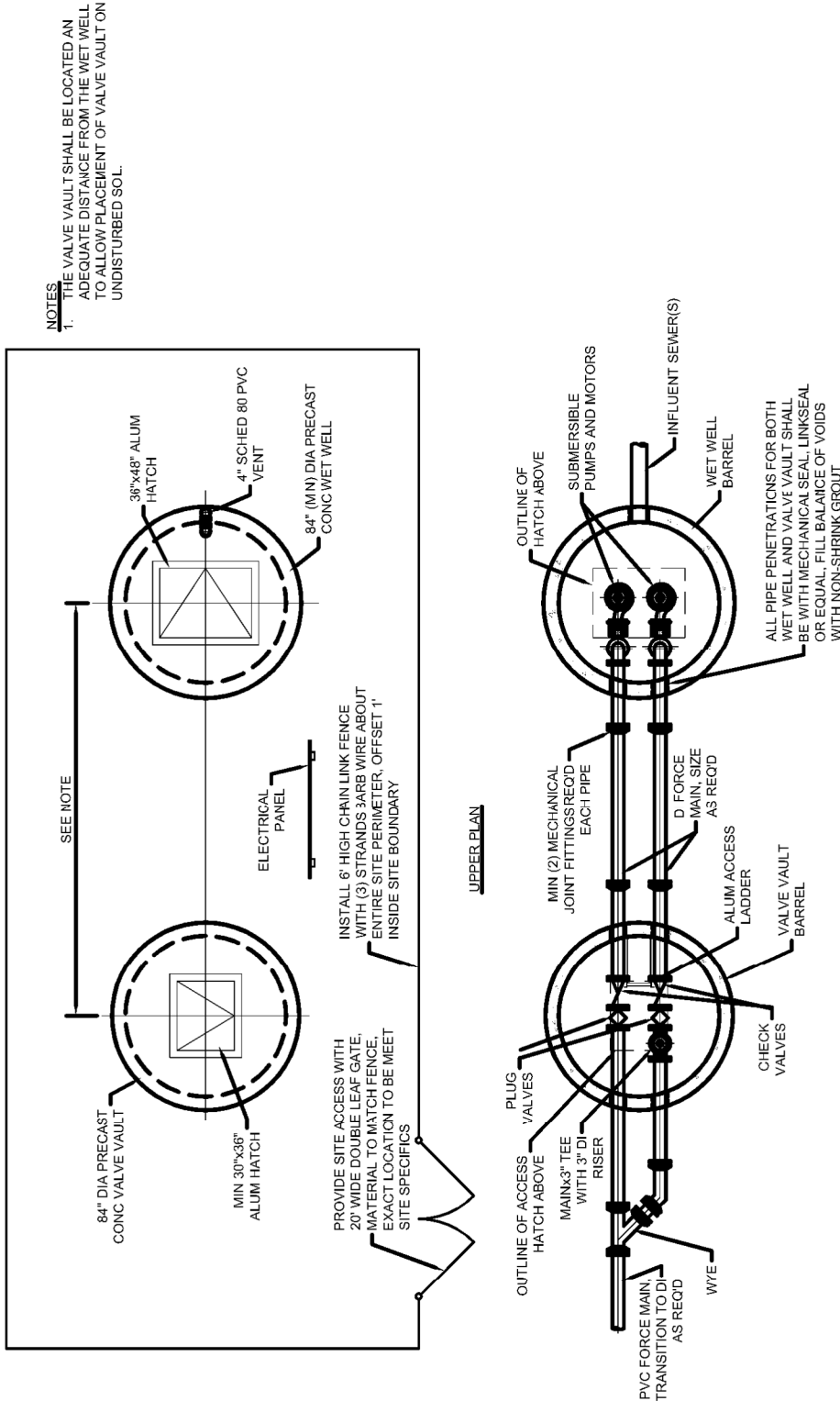

NOTES
1. THE VALVE VAULT SHALL BE LOCATED AN ADEQUATE DISTANCE FROM THE WET WELL TO ALLOW PLACEMENT OF VALVE VAULT ON UNDISTURBED SOL.

TYPICAL 2-PUMP LIFT STATION - PLANS

SCALE: NONE

FIGURE 24
Hebron Public Works Department
Sanitary Sewer Standard Details

Drawing: J:\Hebron\Projects\238721 Hebron Sewer Use Ordinance\CAD\DWG\Sheets\Main-CrossRqrmts.dwg | Layout: Std 1 | Plotted: 04/20/21 @ 12:08:13 | LastSavedBy: AllenS

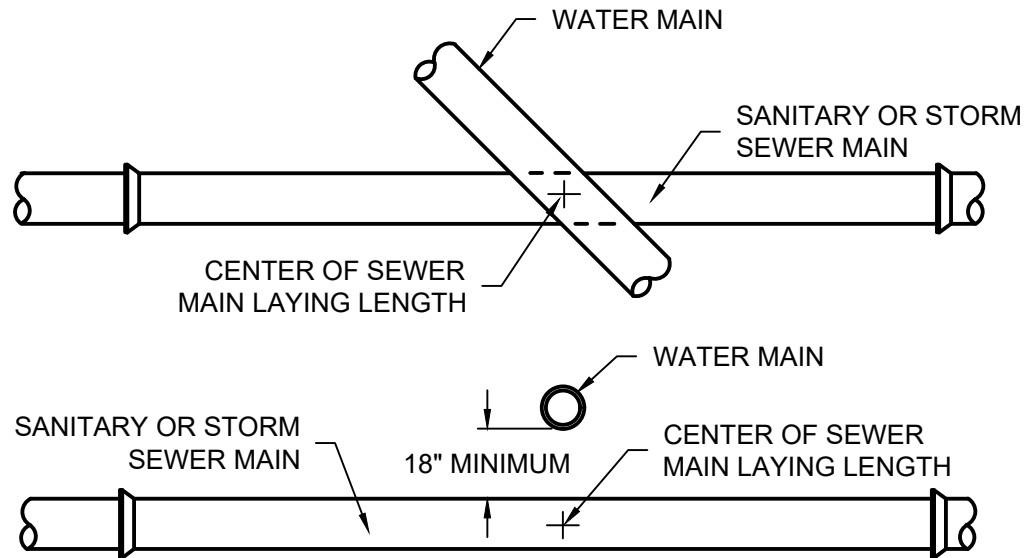

NOTES:

1. WATER MAIN AND SEWER MINIMUM SEPARATION: 18" VERTICAL SEPARATION 10'-0" HORIZONTAL SEPARATION.
2. WHERE WATER MAIN AND SEWER SEPARATION IS LESS THAN 18" VERTICAL OR 10' HORIZONTAL, THE SEWER MUST BE DUCTILE IRON OR SDR-21 PVC.

MINIMUM CROSSOVER AND SEPARATION REQUIREMENTS FOR SEWER AND WATER MAINS

SCALE: NONE



FIGURE 25
Hebron Public Works Department
Sanitary Sewer Standard Details

April 2021

Drawing: J:\Hebron\Projects\238721 Hebron Sewer Use Ordinance\CAD\DWG\Sheets\Ditch Crossing.dwg | Layout: 8.5x11 Std | Plotted: 04/20/21 @ 12:03:03 | LastSavedBy: AllenS

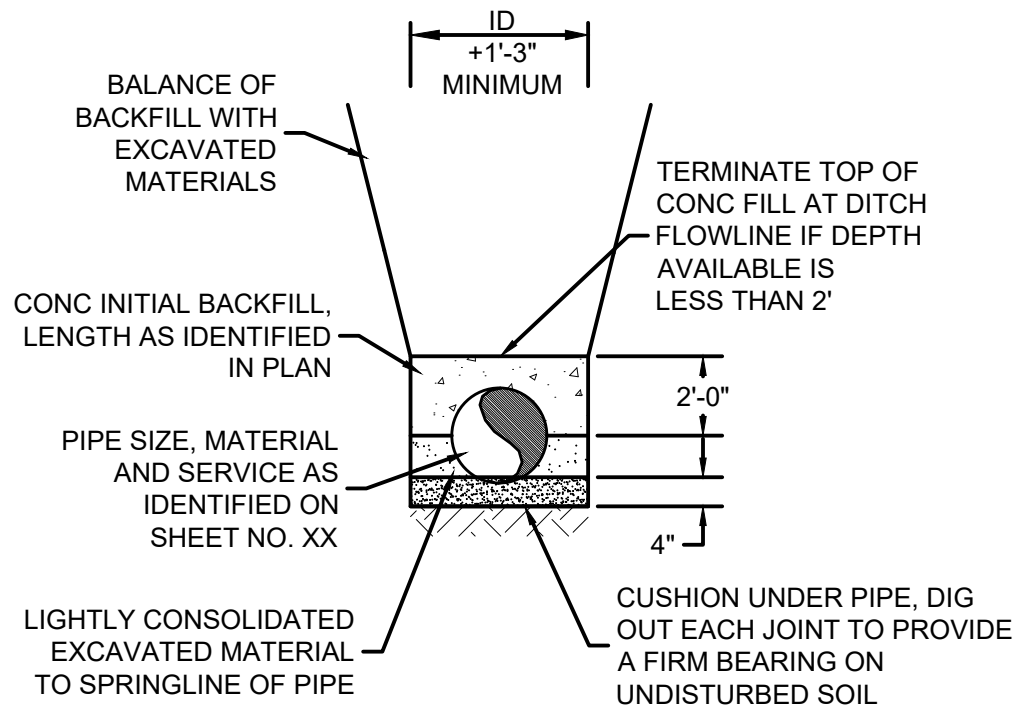

DITCH CROSSING

SCALE: NONE

Drawing: J:\Hebron\Projects\238721 Hebron Sewer Use Ordinance\CAD\DWG\Sheets\StreamCrossing.dwg | Layout: Std 1 | Plotted: 04/27/21 @ 11:38:29 | LastSavedBy: AllenS

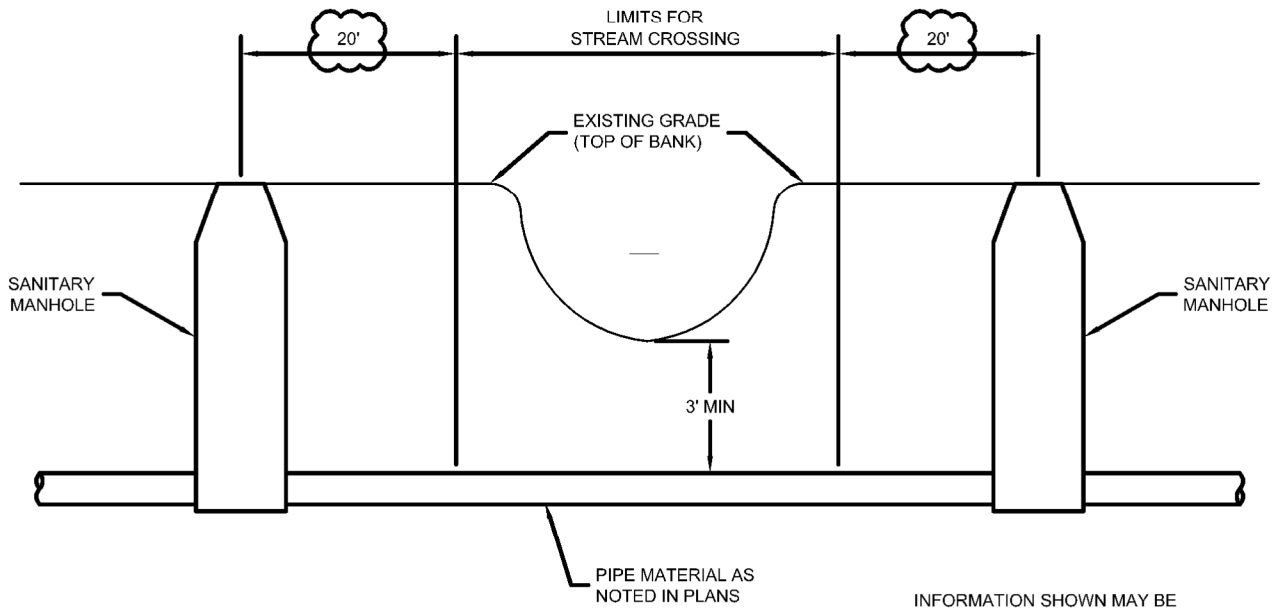

STREAM CROSSING DETAILS

SCALE: NONE



More than a Project™



FIGURE 27

Hebron Public Works Department
Sanitary Sewer Standard Details

April 2021



More than a Project™

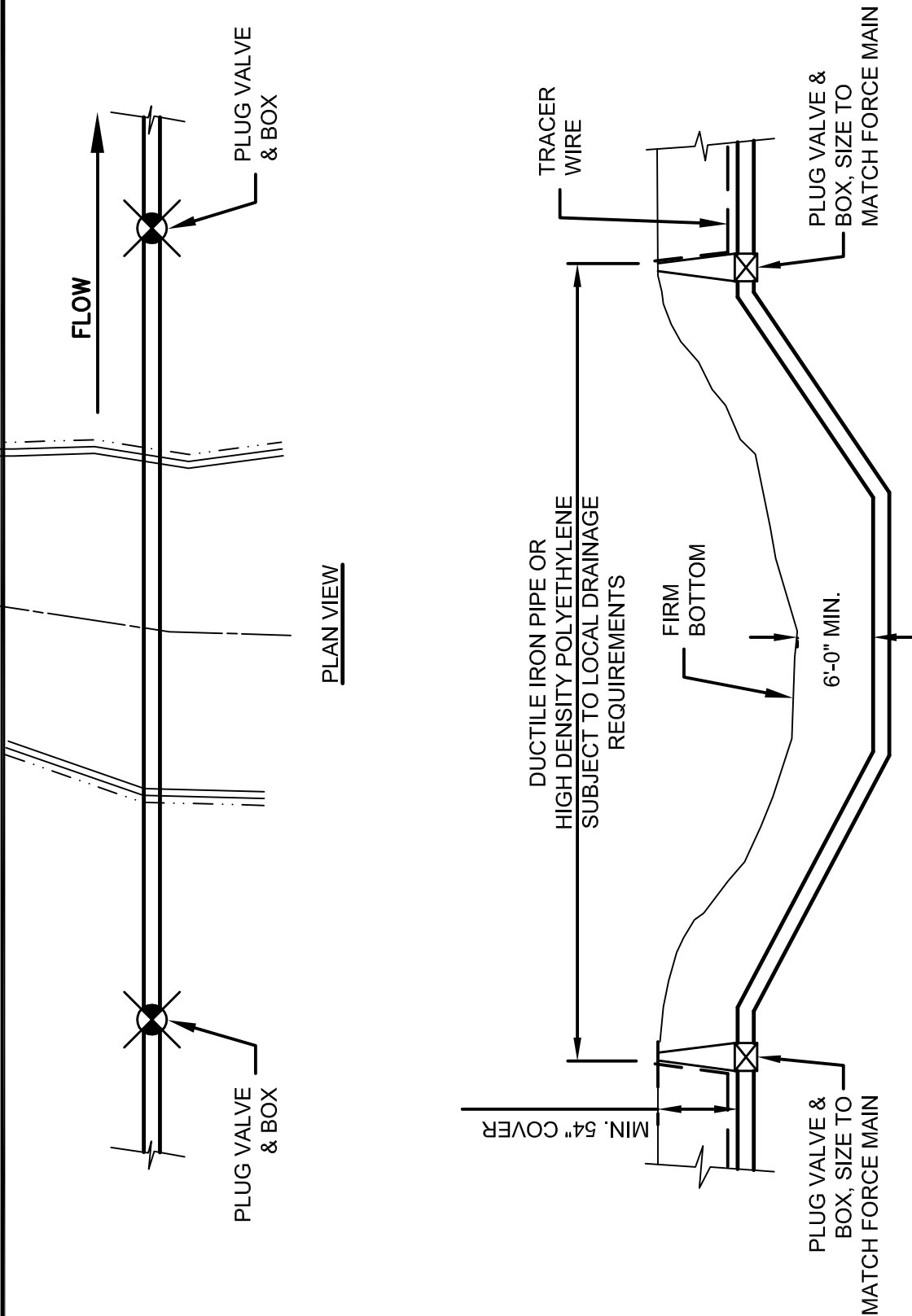

FORCE MAIN STREAM CROSSING DETAILS

SCALE: NONE

FIGURE 28

Hebron Public Works Department
Sanitary Sewer Standard Details

April 2021

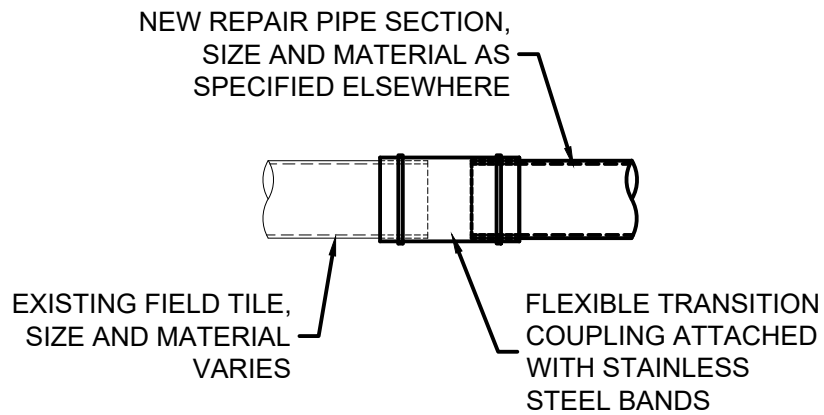

FIELD TILE REPAIR

SCALE: NONE

Drawing: J:\Hebron\Projects\238721 Hebron Sewer Use Ordinance\CAD\DWG\Sheets\Std San MH Frame.dwg | Layout: 8.5x11 Std | Plotted: 04/20/21 @ 11:49:09 | LastSavedBy: Allens

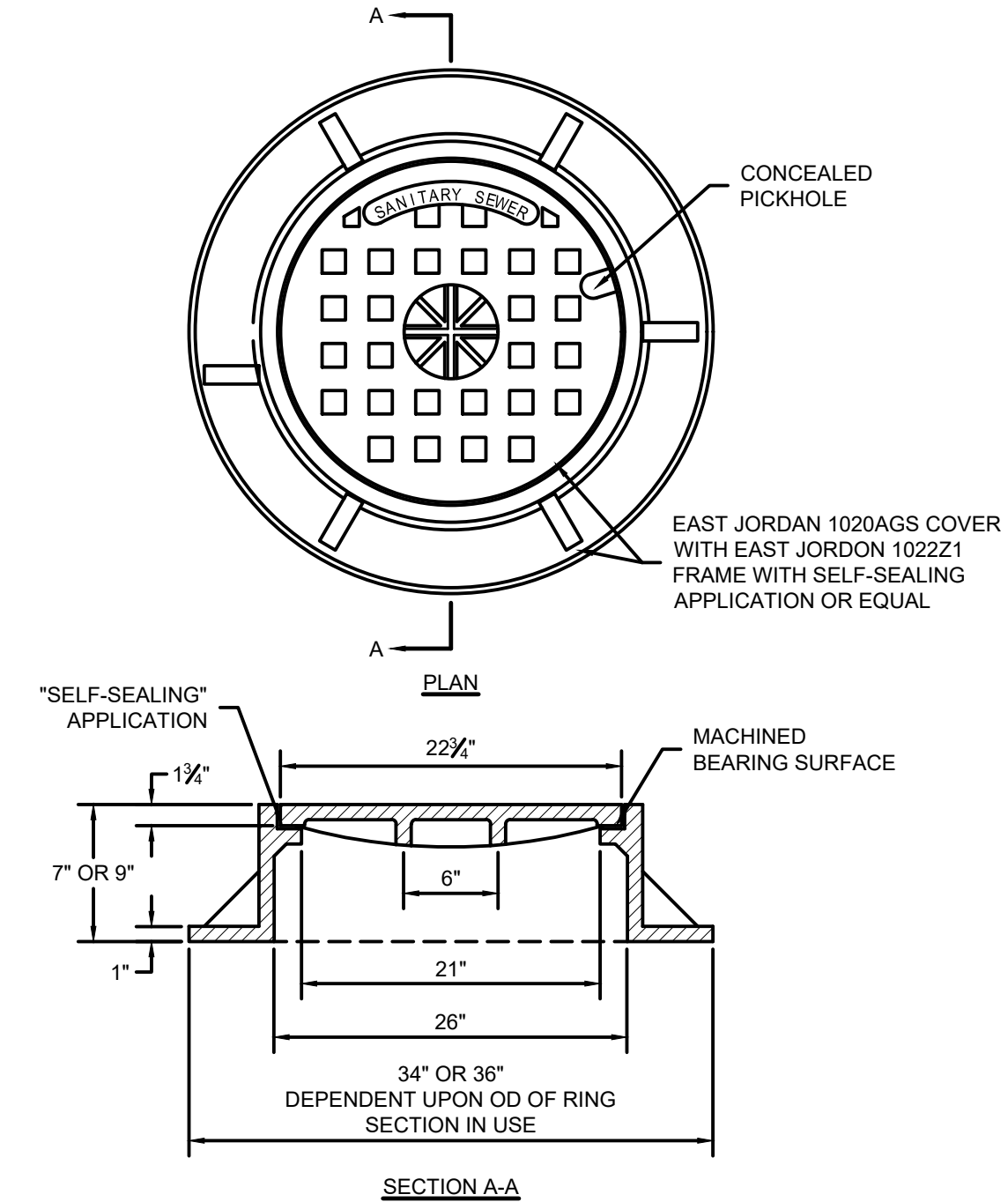

**STANDARD SANITARY SEWER MANHOLE
FRAME AND COVER**

SCALE: NONE



FIGURE 30
Hebron Public Works Department
Sanitary Sewer Standard Details

April 2021

Drawing: J:\Hebron\Projects\238721 Hebron Sewer Use Ordinance\CAD\DWG\Sheets\Std Sanitary Sewer Doghouse MH.dwg | Layout: 8.5x11 Std | Plotted: 04/20/21 @ 11:45:57 | LastSavedBy: AllenS

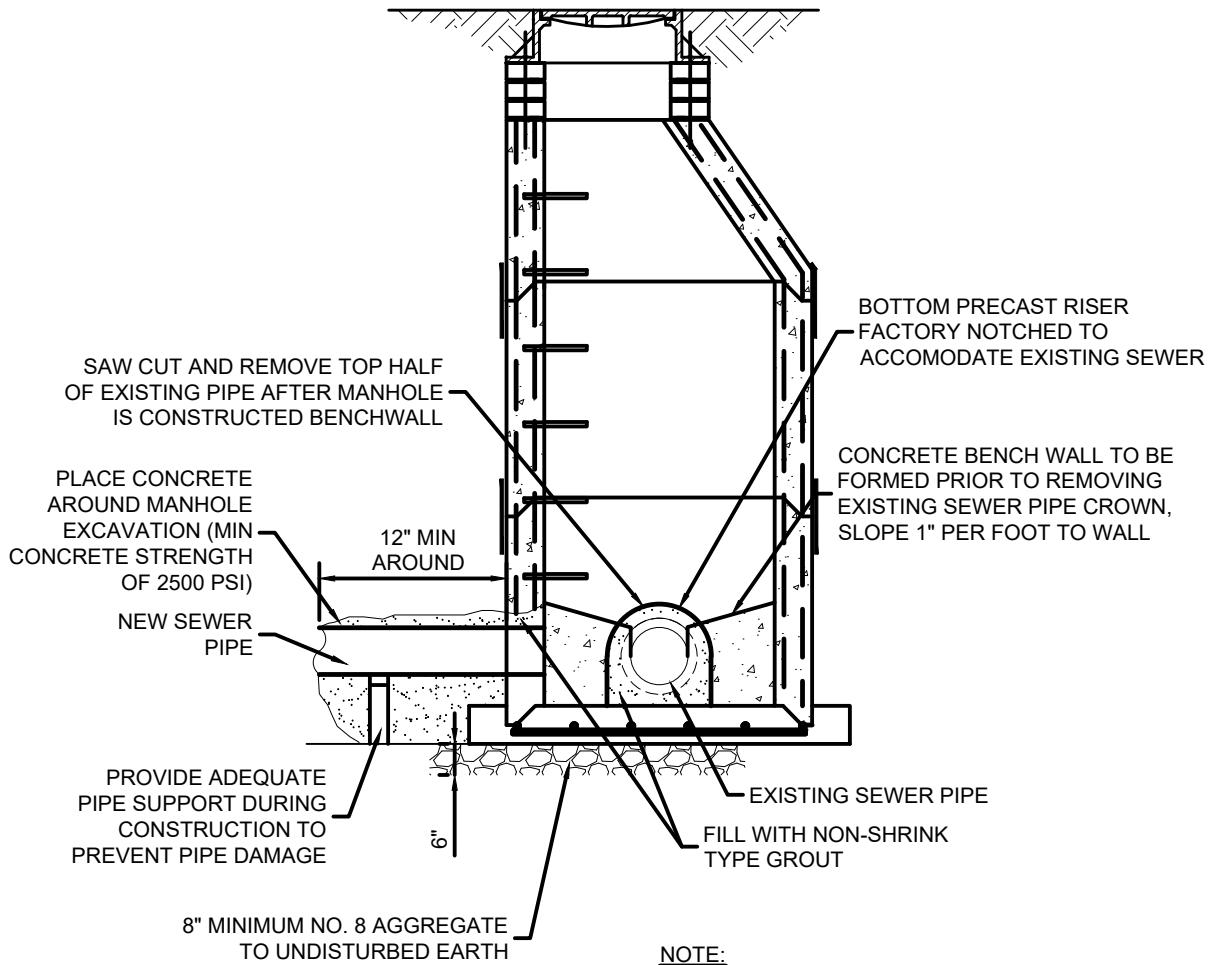

NOTE:
1. MANHOLE CONSTRUCTION AND ACCESSORIES SAME AS SHOWN FOR STANDARD MANHOLE.

SANITARY MANHOLE OVER EXISTING SANITARY SEWER

SCALE: NONE